

i70s Instrument

INSTALLATION & OPERATION INSTRUCTIONS

English (EN)

Date: 05-2016

Document number: 81364-1

© 2016 Raymarine UK Limited



Raymarine[®]
BY  **FLIR**

Printed Manuals

Would you prefer a printed version of this document?

Full documentation for your product is always provided as a free download on the Raymarine website, but some customers prefer manuals in a printed format.



Raymarine provides a Print Shop service which enables you to purchase a printed manual (paperback book), delivered to your door.

www.raymarine.com/printshop



Trademark and patents notice

Raymarine, Tacktick, Clear Pulse, Truzoom, HSB, SeaTalk, SeaTalk^{hs}, SeaTalk^{ng}, Micronet, Raytech, Gear Up, Marine Shield, Seahawk, Autohelm, Automagic, and Visionality are registered or claimed trademarks of Raymarine Belgium.

FLIR, DownVision, SideVision, Dragonfly, Quantum, Instalert, Infrared Everywhere, and The World's Sixth Sense are registered or claimed trademarks of FLIR Systems, Inc.

All other trademarks, trade names, or company names referenced herein are used for identification only and are the property of their respective owners.

This product is protected by patents, design patents, patents pending, or design patents pending.

Fair Use Statement

You may print no more than three copies of this manual for your own use. You may not make any further copies or distribute or use the manual in any other way including without limitation exploiting the manual commercially or giving or selling copies to third parties.

Software updates

Important: Check the Raymarine website for the latest software releases for your product.

www.raymarine.com/software

Product handbooks

The latest versions of all English and translated handbooks are available to download in PDF format from the website www.raymarine.com. Please check the website to ensure you have the latest handbooks.

Copyright ©2016 Raymarine UK Ltd. All rights reserved.





Contents

Chapter 1 Important information.....	7	7.1 Transducer types	40
TFT Displays	7	7.2 Depth calibration	40
Water ingress	7	7.3 Speed calibration	41
Disclaimer	7	7.4 Wind calibration	46
EMC installation guidelines	8	7.5 Rudder reference calibration.....	48
Suppression ferrites	8	7.6 Compass calibration.....	49
Connections to other equipment	8	Chapter 8 Favorite Pages	51
Declaration of conformity.....	8	8.1 Favorite pages	52
Product disposal.....	8	8.2 Customizing pages.....	52
Warranty registration.....	8	Chapter 9 Data (Quick View).....	55
IMO and SOLAS.....	8	9.1 Data items	56
Technical accuracy	8	9.2 Viewing Data (Quick View).....	58
Chapter 2 Document and product information.....	9	9.3 Adding a Quick View as a Favorite page.....	59
2.1 Document information	10	Chapter 10 AIS.....	61
2.2 Product overview	10	10.1 AIS Overview	62
Chapter 3 Planning the installation	11	10.2 AIS target symbols	63
3.1 Installation checklist	12	10.3 Setting AIS Range.....	64
3.2 Parts supplied.....	12	10.4 Viewing AIS target information	64
3.3 Compatible transducers.....	13	10.5 Enabling and disabling AIS Silent mode.....	65
3.4 Software updates	13	Chapter 11 Race timer settings.....	67
3.5 Tools	14	11.1 Setting the Race Timer	68
3.6 Typical systems	14	11.2 Using the Race Timer	68
3.7 System protocols	17	Chapter 12 Instrument alarms.....	69
3.8 Warnings and cautions	17	12.1 Alarms.....	70
3.9 General location requirements	18	Chapter 13 Setup menu	73
3.10 Product dimensions.....	19	13.1 Setup menu	74
Chapter 4 Cables and connections.....	21	Chapter 14 Maintenance	83
4.1 General cabling guidance	22	14.1 Service and maintenance	84
4.2 Connections overview	22	14.2 Routine equipment checks	84
4.3 SeaTalk ^{ng} ® power supply	23	14.3 Product cleaning	85
4.4 Cable ferrite installation	25	14.4 Cleaning the display case	85
4.5 SeaTalk ^{ng} ® connection.....	25	14.5 Cleaning the display screen	86
4.6 NMEA 2000 connection	26	14.6 Cleaning the sun cover	86
4.7 SeaTalk connection	27	Chapter 15 System checks and troubleshooting	87
4.8 Transducer connections	27	15.1 Troubleshooting	88
Chapter 5 Mounting.....	29	15.2 Power up troubleshooting	89
5.1 Bezel removal.....	30	15.3 System data troubleshooting.....	90
5.2 Removing the keypad.....	30	15.4 Miscellaneous troubleshooting	91
5.3 Mounting	31	15.5 Performing a Factory Reset	92
Chapter 6 Getting started	33	Chapter 16 Technical support	93
6.1 Controls.....	34	16.1 Raymarine product support and servicing	94
6.2 Power	34	16.2 Viewing product information	95
6.3 Completing the startup wizard.....	35	Chapter 17 Technical specification.....	97
6.4 Display settings.....	35	17.1 Technical specification	98
6.5 Multiple data sources (MDS) overview.....	37	Chapter 18 Options and accessories	99
6.6 Quick Options menu.....	38		
Chapter 7 Transducer calibration	39		

18.1 Spares and Accessories	100
18.2 Smart transducers	100
18.3 Instrument Depth, Speed and Temperature (DST) transducers	101
18.4 Instrument Depth transducers	102
18.5 Instrument Speed and Temperature transducers	102
18.6 Instrument Wind Vane transducer	103
18.7 Instrument Rotavecta transducer	103
18.8 Other transducers	104
18.9 SeaTalk ^{ng} ® cables and accessories	104
18.10 SeaTalk ^{ng} cable kits	106
18.11 SeaTalk accessories	109

Appendix A Supported NMEA 2000 PGN list	111
--	------------



Chapter 1: Important information



Warning: Product installation and operation

- This product must be installed and operated in accordance with the instructions provided. Failure to do so could result in personal injury, damage to your vessel and/or poor product performance.
- Raymarine recommends certified installation by a Raymarine approved installer. A certified installation qualifies for enhanced product warranty benefits. Contact your Raymarine dealer for further details, and refer to the separate warranty document packed with your product.



Warning: Potential ignition source

This product is NOT approved for use in hazardous/flammable atmospheres. Do NOT install in a hazardous/flammable atmosphere (such as in an engine room or near fuel tanks).



Warning: Product grounding

Before applying power to this product, ensure it has been correctly grounded, in accordance with the instructions provided.



Warning: Positive ground systems

Do not connect this unit to a system which has positive grounding.



Warning: Switch off power supply

Ensure the vessel's power supply is switched OFF before starting to install this product. Do NOT connect or disconnect equipment with the power switched on, unless instructed in this document.



Warning: Power supply voltage

Connecting this product to a voltage supply greater than the specified maximum rating may cause permanent damage to the unit. Refer to the *Technical specification* section for voltage rating.

Caution: Power supply protection

When installing this product ensure the power source is adequately protected by means of a suitably-rated fuse or automatic circuit breaker.

Caution: Sun covers

- If your product is supplied with a sun cover, to protect against the damaging effects of ultraviolet (UV) light, always fit the sun cover when the product is not in use.
- Sun covers must be removed when travelling at high speed, whether in water or when the vessel is being towed.

Caution: Product cleaning

When cleaning products:

- If your product includes a display screen, do NOT wipe the screen with a dry cloth, as this could scratch the screen coating.
- Do NOT use abrasive, or acid or ammonia based products.
- Do NOT use a jet wash.

Caution: Service and maintenance

This product contains no user serviceable components. Please refer all maintenance and repair to authorized Raymarine dealers. Unauthorized repair may affect your warranty.

TFT Displays

The colors of the display may seem to vary when viewed against a colored background or in colored light. This is a perfectly normal effect that can be seen with all color Thin Film Transistor (TFT) displays.

Water ingress

Water ingress disclaimer

Although the waterproof rating capacity of this product meets the stated IPX standard (refer to the product's *Technical Specification*), water intrusion and subsequent equipment failure may occur if the product is subjected to commercial high-pressure washing. Raymarine will not warrant products subjected to high-pressure washing.

Disclaimer

Raymarine does not warrant that this product is error-free or that it is compatible with products manufactured by any person or entity other than Raymarine.

Raymarine is not responsible for damages or injuries caused by your use or inability to use the product, by the interaction of the product with products manufactured by others, or by errors in information utilized by the product supplied by third parties.

EMC installation guidelines

Raymarine equipment and accessories conform to the appropriate Electromagnetic Compatibility (EMC) regulations, to minimize electromagnetic interference between equipment and minimize the effect such interference could have on the performance of your system

Correct installation is required to ensure that EMC performance is not compromised.

Note: In areas of extreme EMC interference, some slight interference may be noticed on the product. Where this occurs the product and the source of the interference should be separated by a greater distance.

For **optimum** EMC performance we recommend that wherever possible:

- Raymarine equipment and cables connected to it are:
 - At least 1 m (3 ft) from any equipment transmitting or cables carrying radio signals e.g. VHF radios, cables and antennas. In the case of SSB radios, the distance should be increased to 7 ft (2 m).
 - More than 2 m (7 ft) from the path of a radar beam. A radar beam can normally be assumed to spread 20 degrees above and below the radiating element.
- The product is supplied from a separate battery from that used for engine start. This is important to prevent erratic behavior and data loss which can occur if the engine start does not have a separate battery.
- Raymarine specified cables are used.
- Cables are not cut or extended, unless doing so is detailed in the installation manual.

Note: Where constraints on the installation prevent any of the above recommendations, always ensure the maximum possible separation between different items of electrical equipment, to provide the best conditions for EMC performance throughout the installation

Suppression ferrites

- Raymarine cables may be pre-fitted or supplied with suppression ferrites. These are important for correct EMC performance. If ferrites are supplied separately to the cables (i.e. not pre-fitted), you must fit the supplied ferrites, using the supplied instructions.
- If a ferrite has to be removed for any purpose (e.g. installation or maintenance), it must be replaced in the original position before the product is used.
- Use only ferrites of the correct type, supplied by Raymarine or its authorized dealers.
- Where an installation requires multiple ferrites to be added to a cable, additional cable clips should be used to prevent stress on the connectors due to the extra weight of the cable.

Connections to other equipment

Requirement for ferrites on non-Raymarine cables

If your Raymarine equipment is to be connected to other equipment using a cable not supplied by Raymarine, a suppression ferrite **MUST** always be attached to the cable near the Raymarine unit.

Declaration of conformity

Raymarine UK Ltd. declares that this product is compliant with the essential requirements of EMC directive 2004/108/EC.

The original Declaration of Conformity certificate may be viewed on the relevant product page at www.raymarine.com.

Product disposal

Dispose of this product in accordance with the WEEE Directive.



The Waste Electrical and Electronic Equipment (WEEE) Directive requires the recycling of waste electrical and electronic equipment.

Warranty registration

To register your Raymarine product ownership, please visit www.raymarine.com and register online.

It is important that you register your product to receive full warranty benefits. Your unit package includes a bar code label indicating the serial number of the unit. You will need this serial number when registering your product online. You should retain the label for future reference.

IMO and SOLAS

The equipment described within this document is intended for use on leisure marine boats and workboats NOT covered by International Maritime Organization (IMO) and Safety of Life at Sea (SOLAS) Carriage Regulations.

Technical accuracy

To the best of our knowledge, the information in this document was correct at the time it was produced. However, Raymarine cannot accept liability for any inaccuracies or omissions it may contain. In addition, our policy of continuous product improvement may change specifications without notice. As a result, Raymarine cannot accept liability for any differences between the product and this document. Please check the Raymarine website (www.raymarine.com) to ensure you have the most up-to-date version(s) of the documentation for your product.

Chapter 2: Document and product information

Chapter contents

- [2.1 Document information on page 10](#)
- [2.2 Product overview on page 10](#)



2.1 Document information

This document contains important information related to the installation of your Raymarine product.

The document includes information to help you:

- plan your installation and ensure you have all the necessary equipment;
- install and connect your product as part of a wider system of connected marine electronics;
- troubleshoot problems and obtain technical support if required.

This and other Raymarine product documents are available to download in PDF format from www.raymarine.com.

Applicable products

This document is applicable to the following products:

	Part number	Name	Description
	E70327	i70s	multifunction Instrument display

Document illustrations

Your product may differ slightly from that shown in the illustrations in this document, depending on product variant and date of manufacture.

All images are provided for illustration purposes only.

Product documentation

The following documentation is applicable to your product:

Description	Part number
i70s Installation and operation instructions Installation and operation instructions for the i70s unit and connection to a wider system of marine electronics.	88056 / 81357
i70s Mounting template Mounting diagram for surface mounting a i70s unit.	87260

Additional documentation

Description	Part number
SeaTalk^{ng}® reference manual	81300
iTC-5 Installation instructions	87138

2.2 Product overview

The **i70s** is a multifunctional instrument display with AIS capabilities. In conjunction with a compatible instrument transducers and an **iTC-5**, the **i70s** provides a detailed view of environmental, navigational and vessel data.

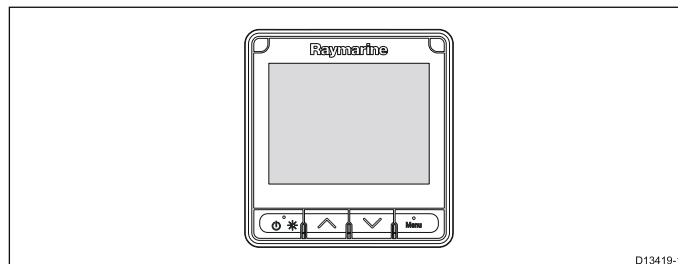

The i70s has the following features:

- 4.1" high brightness color LCD with wide viewing angles
- **SeaTalk^{ng}®**, **NMEA 2000** and **SeaTalk** compatible
- All weather optically bonded LCD
- Large clear characters (up to 43 mm / 1.7 in) for easy reading in any conditions
- Easy to use **LightHouse™** operating system
- AIS repeater and display of AIS targets
- Data views include: Wind, Speed, Depth, Tridata, Engine, Environment, Fuel and Navigation
- 12 V dc operation
- Low power consumption
- Waterproof to IPX6 and IPX7

Chapter 3: Planning the installation

Chapter contents

- 3.1 Installation checklist on page 12
- 3.2 Parts supplied on page 12
- 3.3 Compatible transducers on page 13
- 3.4 Software updates on page 13
- 3.5 Tools on page 14
- 3.6 Typical systems on page 14
- 3.7 System protocols on page 17
- 3.8 Warnings and cautions on page 17
- 3.9 General location requirements on page 18
- 3.10 Product dimensions on page 19



3.1 Installation checklist

Installation includes the following activities:

Installation Task	
1	Plan your system.
2	Obtain all required equipment and tools.
3	Site all equipment.
4	Route all cables.
5	Drill cable and mounting holes.
6	Make all connections into equipment.
7	Secure all equipment in place.
8	Power on and test the system.

Schematic diagram

A schematic diagram is an essential part of planning any installation. It is also useful for any future additions or maintenance of the system. The diagram should include:

- Location of all components.
- Connectors, cable types, routes and lengths.

3.2 Parts supplied

The following parts are supplied with your product.

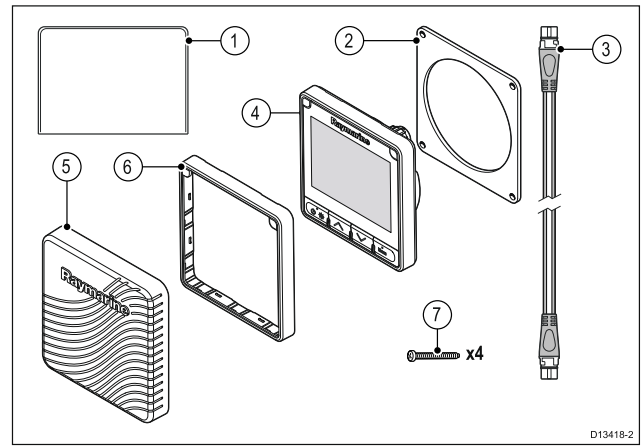

1. Documentation
2. Panel seal gasket
3. 400 mm (15.7 in) **SeaTalkng®** spur cable (A06038)
4. **i70s** instrument display (supplied with keymat and black bezel (A80353) fitted)
5. Suncover (A80357)
6. Spare gunmetal bezel (A80354)
7. Mounting fixings x 4

Unpack your product carefully to prevent damage or loss of parts, check the box contents against the list above. Retain the packaging and documentation for future reference.

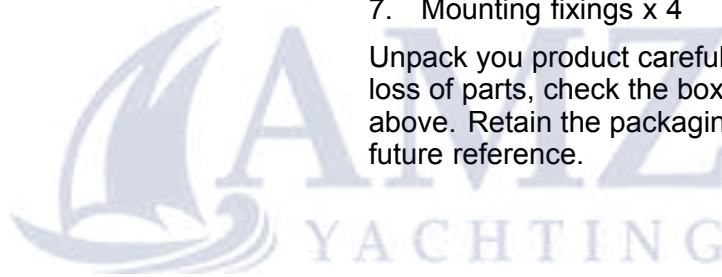

3.3 Compatible transducers

For a list of compatible transducers please refer to [Chapter 18 Options and accessories](#).

3.4 Software updates

The software running on the product can be updated.

- Raymarine periodically releases software updates to improve product performance and add new features.
- You can update the software for your product using a connected and compatible multifunction display.
- Refer to www.raymarine.com/software/ for the latest software updates and the software update procedure for your product.
- If in doubt as to the correct procedure for updating your product software, refer to your dealer or Raymarine technical support.

Caution: Installing software updates

The software update process is carried out at your own risk. Before initiating the update process ensure you have backed up any important files.

Ensure that the unit has a reliable power supply and that the update process is not interrupted.

Damage caused by incomplete updates are not covered by Raymarine warranty.

By downloading the software update package, you agree to these terms.



3.5 Tools

Tools required for installation

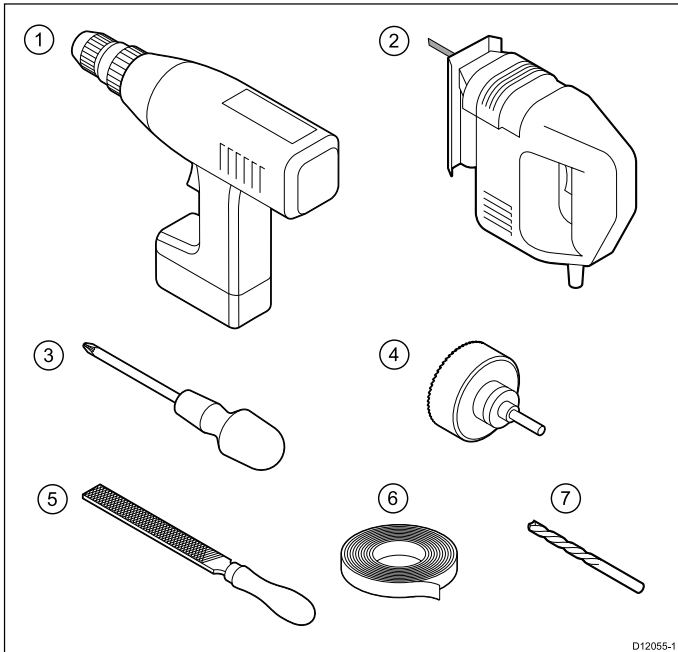

1.	Power drill
2.	Jig saw
3.	Screwdriver
4.	Suitable size (10 mm to 30 mm) hole cutter
5.	File
6.	Adhesive tape
7.	Drill bit of appropriate size (1)

Note: (1) Drill bit size is dependent on the thickness and type of material that the unit is to be mounted on.

3.6 Typical systems

The following illustrations show the products that can be connected in a typical system.

Example: Simple environmental data system

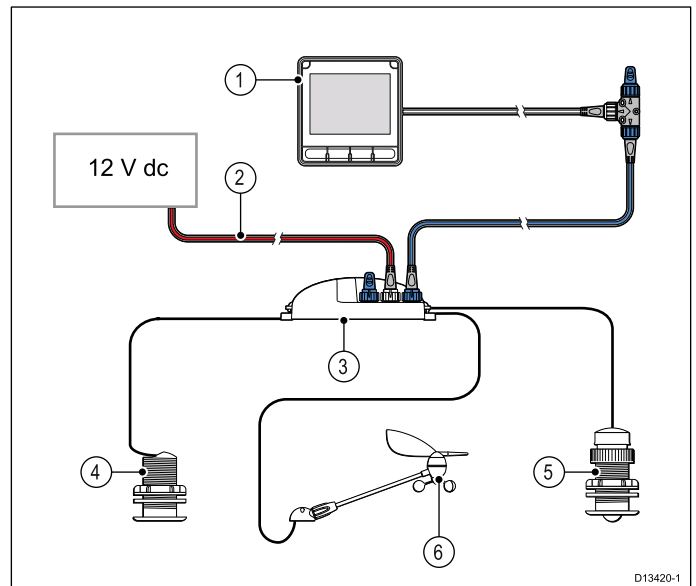

Item	Description
1	Instrument display (e.g. i70s)
2	SeaTalk ^{ng} ® 12 V dc power supply
3	iTC-5 converter
4	Depth transducer (Analog)
5	Speed / Temperature transducer (Analog)
6	Wind transducer (Analog)

Example: Expanded system without autopilot

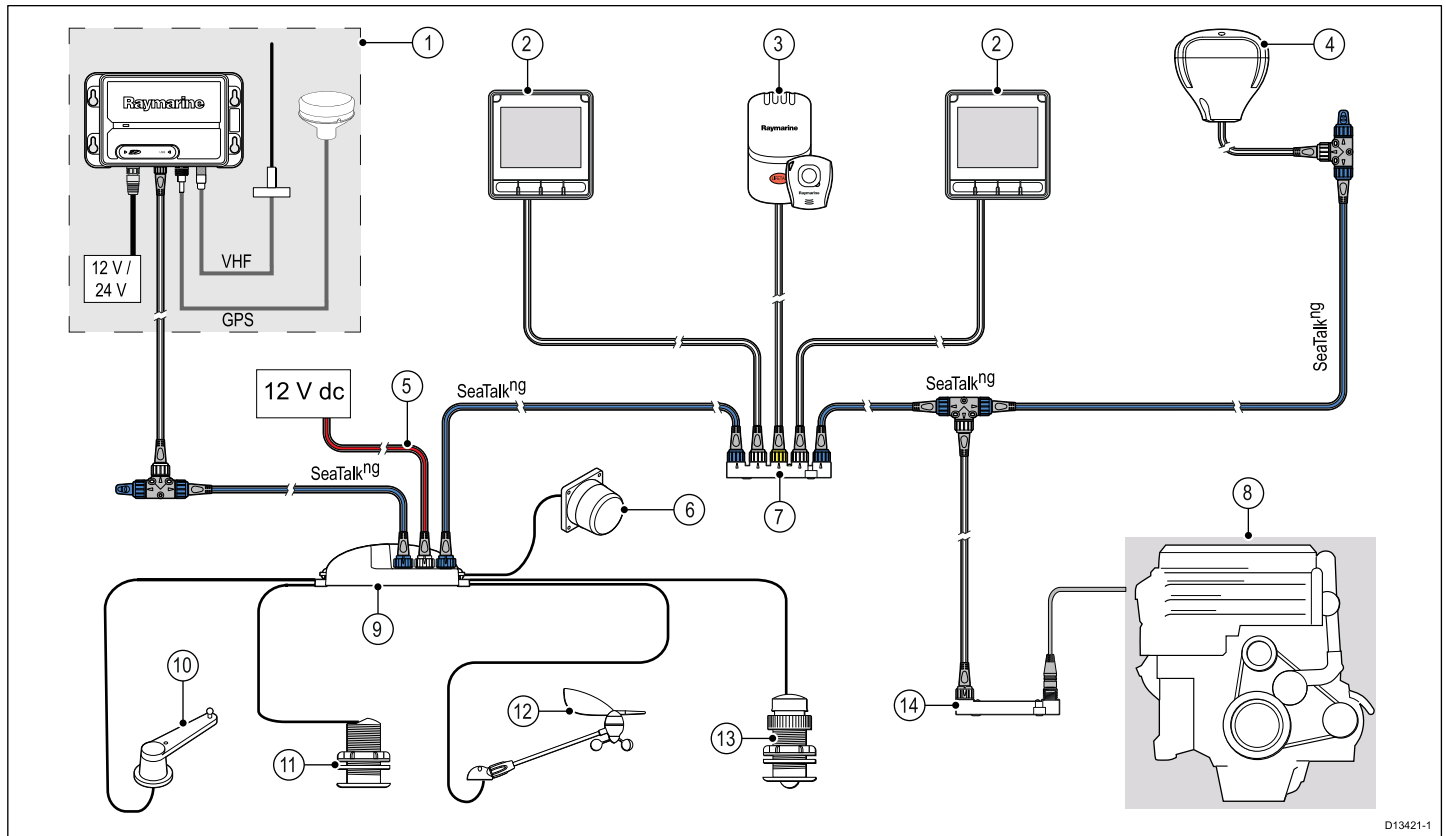

D13421-1

Item	Description
1	AIS receiver / transceiver (AIS350 / AIS650)
2	Instrument display (e.g. i70s)
3	LifeTag — Man Over Board (MOB) system
4	SeaTalkng® GPS/GNSS Receiver (e.g. RS130)
5	SeaTalkng® 12 V dc power supply
6	Fluxgate compass
7	SeaTalk to SeaTalkng® converter
8	Vessel / Engine systems
9	iTC-5 converter
10	Rudder reference
11	Depth transducer (Analog)
12	Wind transducer (Analog)
13	Speed / Temperature transducer (Analog)
14	ECI-100
	<p>Note: Depending on engine type, it may be possible to connect the engine system directly to the SeaTalkng® backbone using a SeaTalkng® to DeviceNet adaptor cable. Without using the ECI-100 the available data will be limited to supported, standard NMEA 2000 data only.</p>

Example: Expanded system with autopilot

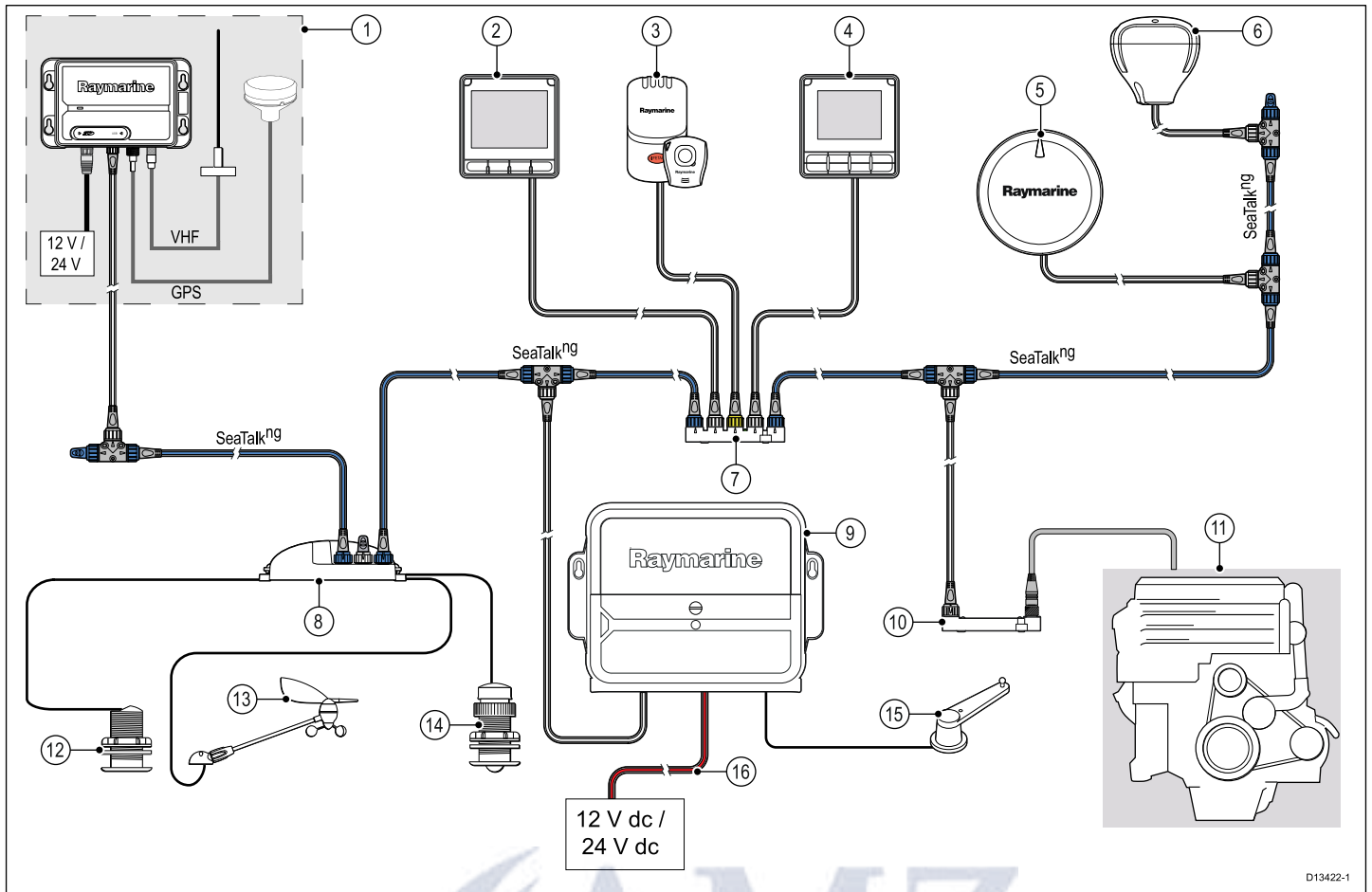

D13422-1

Item	Description
1	AIS receiver / transceiver (AIS350 / AIS650)
2	Instrument display (e.g. i70s)
3	LifeTag — Man Over Board (MOB) system
4	Pilot Controller (e.g. p70s or p70Rs)
5	Evolution™ Autopilot
6	SeaTalkng® GPS/GNSS Receiver (e.g. RS130)
7	SeaTalk to SeaTalkng® converter
8	iTC-5 converter
9	ACU (Autopilot Control Unit)
10	ECI-100 Note: Depending on engine type, it may be possible to connect the engine system directly to the SeaTalkng® backbone using a SeaTalkng® to DeviceNet adaptor cable. Without using the ECI-100 the available data will be limited to supported, standard NMEA 2000 data only.
11	Vessel / Engine systems
12	Depth transducer (Analog)
13	Wind transducer (Analog)
14	Speed / Temperature transducer (Analog)
15	Rudder reference
16	12 V dc / 24 V dc power supply (powering the SeaTalkng® backbone.)

3.7 System protocols

Your product can be connected to various products and systems to share information and so improve the functionality of the overall system. These connections may be made using a number of different protocols. Fast and accurate data collection and transfer is achieved by using a combination of the following data protocols:

- **SeaTalk^{ng}**
- **NMEA 2000**
- **SeaTalk**

Note: You may find that your system does not use all of the connection types or instrumentation described in this section.

Seataalk^{ng}

SeaTalk^{ng} (Next Generation) is an enhanced protocol for connection of compatible marine instruments and equipment. It replaces the older **SeaTalk** and **SeaTalk²** protocols.

SeaTalk^{ng} utilizes a single backbone to which compatible instruments connect using a spur. Data and power are carried within the backbone. Devices that have a low draw can be powered from the network, although high current equipment will need to have a separate power connection.

SeaTalk^{ng} is a proprietary extension to **NMEA 2000** and the proven CAN bus technology. Compatible **NMEA 2000** and **SeaTalk / SeaTalk²** devices can also be connected using the appropriate interfaces or adaptor cables as required.

NMEA 2000

NMEA 2000 offers significant improvements over **NMEA 0183**, most notably in speed and connectivity. Up to 50 units can simultaneously transmit and receive on a single physical bus at any one time, with each node being physically addressable. The standard was specifically intended to allow for a whole network of marine electronics from any manufacturer to communicate on a common bus via standardized message types and formats.

SeaTalk

SeaTalk is a protocol which enables compatible instruments to connect to each other and share data.

The **SeaTalk** cable system is used to connect compatible instruments and equipment. The cable carries power and data and enables connection without the need for a central processor.

Additional instruments and functions can be added to a **SeaTalk** system, simply by plugging them into the network. **SeaTalk** equipment can also communicate with other non-SeaTalk equipment via the **NMEA 0183** standard, provided a suitable interface is used.

3.8 Warnings and cautions

Important: Before proceeding, ensure that you have read and understood the warnings and cautions provided in the [Chapter 1 Important information](#) section of this document.

3.9 General location requirements

Important considerations when choosing a suitable location for your product.

This product is suitable for mounting above or below decks.

The product should be mounted where it will be:

- protected from physical damage and excessive vibration.
- well ventilated and away from heat sources.
- away from any potential ignition source such as an engine room, near fuel tanks or a gas locker.

When choosing a location for the product, consider the following points to ensure reliable and trouble-free operation:

- **Access** — there must be sufficient space to enable cable connections to the product, avoiding tight bends in the cable.
- **Diagnostics** — the product must be mounted in a location where the diagnostics LED is easily visible.

Note: Not all products include a diagnostics LED. Refer to the [Chapter 15 System checks and troubleshooting](#) for more information.

- **Electrical interference** — the product should be mounted far enough away from any equipment that may cause interference such as motors, generators and radio transmitters / receivers.
- **Magnetic compass** — refer to the *Compass safe distance* section in this document for advice on maintaining a suitable distance between this product and any compasses on your vessel.
- **Power** — to keep cable runs to a minimum, the product must be located as close as possible to the vessel's dc power supply.
- **Mounting surface** — ensure the product is adequately supported on a secure surface. Refer to the weight information provided in the *Technical specification* for this product and ensure that the intended mounting surface is suitable for bearing the product weight. Do NOT mount units or cut holes in places which may damage the structure of the vessel.

Compass safe distance

To prevent potential interference with the vessel's magnetic compasses, ensure an adequate distance is maintained from the product.

When choosing a suitable location for the product you should aim to maintain the maximum possible distance from any compasses. Typically this distance should be at least 1 m (3 ft) in all directions. However for some smaller vessels it may not be possible to locate the product this far away from a compass. In this situation, when choosing the installation location for your product, ensure that the compass is not affected by the product when it is in a powered state.

Viewing angle considerations

As display contrast, color and night mode performance are all affected by the viewing angle, Raymarine recommends you temporarily power up the display when planning the installation, to enable you to best judge which location gives the optimum viewing angle.

3.10 Product dimensions

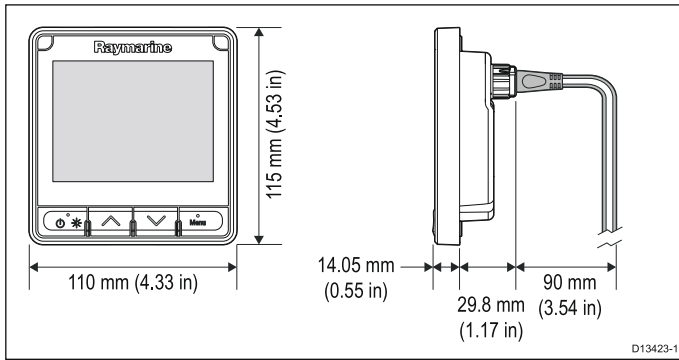



Chapter 4: Cables and connections

Chapter contents

- 4.1 General cabling guidance on page 22
- 4.2 Connections overview on page 22
- 4.3 SeaTalk^{ng}® power supply on page 23
- 4.4 Cable ferrite installation on page 25
- 4.5 SeaTalk^{ng}® connection on page 25
- 4.6 NMEA 2000 connection on page 26
- 4.7 SeaTalk connection on page 27
- 4.8 Transducer connections on page 27



4.1 General cabling guidance

Cable types and length

It is important to use cables of the appropriate type and length

- Unless otherwise stated use only standard cables of the correct type, supplied by Raymarine.
- Ensure that any non-Raymarine cables are of the correct quality and gauge. For example, longer power cable runs may require larger wire gauges to minimize voltage drop along the run.

Routing cables

Cables must be routed correctly, to maximize performance and prolong cable life.

- Do NOT bend cables excessively. Wherever possible, ensure a minimum bend diameter of 200 mm (8 in) / minimum bend radius of 100 mm (4 in).

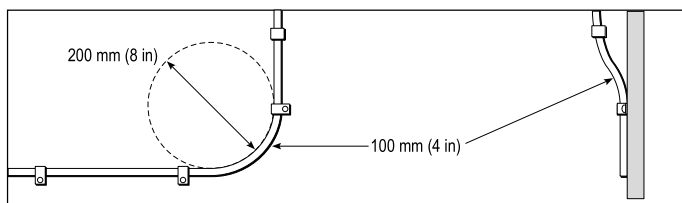

- Protect all cables from physical damage and exposure to heat. Use trunking or conduit where possible. Do NOT run cables through bilges or doorways, or close to moving or hot objects.
- Secure cables in place using tie-wraps or lacing twine. Coil any extra cable and tie it out of the way.
- Where a cable passes through an exposed bulkhead or deckhead, use a suitable watertight feed-through.
- Do NOT run cables near to engines or fluorescent lights.

Always route data cables as far away as possible from:

- other equipment and cables,
- high current carrying AC and DC power lines,
- antennae.

Strain relief

Ensure adequate strain relief is provided. Protect connectors from strain and ensure they will not pull out under extreme sea conditions.

Cable shielding

Ensure that all data cables are properly shielded that the cable shielding is intact (e.g. hasn't been scraped off by being squeezed through a tight area).

4.2 Connections overview

Use the following information to help you identify the connections on your product.

Connector	Qty	Connects to:	Suitable cables
	1	<ol style="list-style-type: none"> 1. SeaTalk^{ng} backbone 2. NMEA 2000 backbone 3. SeaTalk backbone 	<ol style="list-style-type: none"> 1. SeaTalk^{ng} spur cables 2. SeaTalk^{ng} to DeviceNet adaptor cable (A06045) 3. SeaTalk to SeaTalk^{ng} adaptor cable (A06073)

Connecting SeaTalk^{ng}® cables

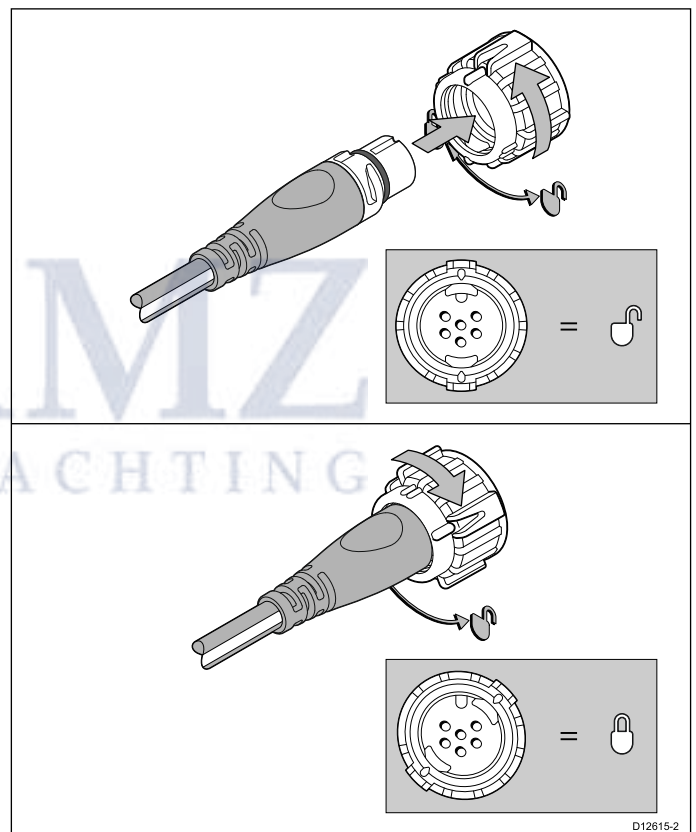

1. Rotate the locking collar on the unit to the unlocked position.
2. Ensure the cable's connector is correctly oriented.
3. Fully insert the cable connector.
4. Rotate locking collar clockwise (2 clicks) until it is in the locked position.

SeaTalk^{ng}® product loading

The number of products that can be connected to a **SeaTalk^{ng}** backbone depends on the power consumption of each product and the physical overall length of the backbone.

SeaTalk^{ng} products have a Load Equivalency Number (LEN), which indicates the product's power consumption. The LEN for each product can be found in the product's Technical Specification.

4.3 SeaTalk^{ng}® power supply

Power is supplied to the product over the **SeaTalk^{ng}** backbone.

A **SeaTalk^{ng}** backbone requires one 12 V dc power supply, connected to the **SeaTalk^{ng}** backbone. This can be provided by:

- a battery ⁽¹⁾, via the distribution panel
- an Autopilot Control Unit (**ACU**)⁽²⁾
- an **SPX** course computer ⁽²⁾
- for 24 V vessels a 5 amp, regulated, continuous 24 V dc to 12 V dc is required

Note:

- (1) The battery used for starting the vessel's engine should NOT be used to power the **SeaTalk^{ng}** backbone as this can cause sudden voltage drops, when starting the engine.
- (2) The **ACU-100** and **SPX-5** cannot be used to power the **SeaTalk^{ng}** backbone.

SeaTalk^{ng}® power connection point

Small systems

If the backbone length is 60 m (197 ft) or less, the power connection point may be connected at any point in the backbone.

Large systems

If the backbone length is greater than 60 m (197 ft), the power connection point should be connected at a point that creates a balanced current draw from each side of the backbone. The Load Equivalency Number (LEN) is used to determine the power connection point for the system.

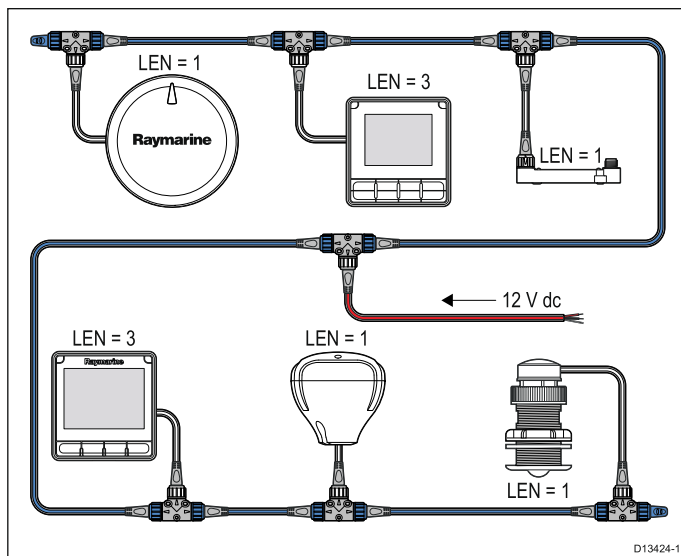

In the example above the system has an overall LEN of 10, so the optimum connection point would be to have 5 LEN either side of the connection point.

In-line fuse and thermal breaker ratings

The **SeaTalk^{ng}** network's power supply requires an in-line fuse or thermal breaker to be fitted.

In-line fuse rating	Thermal breaker rating
5 A	3 A (if only connecting one device)

Note:

- The suitable fuse rating for the thermal breaker is dependent on the number of devices you are connecting. If in doubt consult an authorized Raymarine dealer.

SeaTalk^{ng}® system loading

The maximum loading / LEN for a **SeaTalk^{ng}** system depends on the length of the backbone.

Loading type	Backbone length	Total LEN
Unbalanced	20 m (66 ft)	40
Unbalanced	40 m (131 ft)	20
Unbalanced	60 m (197 ft)	14
Balanced	60 m (197 ft) or less	100
Balanced	80 m (262 ft)	84
Balanced	100 m (328 ft)	60
Balanced	120 m (394 ft)	50
Balanced	140 m to 160 m (459 ft to 525 ft)	40
Balanced	180 m to 200 m (591 ft to 656 ft)	32

Power distribution — SeaTalk^{ng}®

Recommendations and best practice.

- Only use approved **SeaTalk^{ng}** power cables. Do NOT use a power cable designed for, or supplied with, a different product.
- See below for more information on implementation for some common power distribution scenarios.

Important: When planning and wiring, take into consideration other products in your system, some of which (e.g. sonar modules) may place large power demand peaks on the vessel's electrical system.

Note: The information provided below is for guidance only, to help protect your product. It covers common vessel power arrangements, but does NOT cover every scenario. If you are unsure how to provide the correct level of protection, please consult an authorized Raymarine dealer or a suitably qualified professional marine electrician.

Implementation — direct connection to battery

- **SeaTalk^{ng}** power cables may be connected directly to the vessel's battery, via a suitably rated fuse or breaker.

- You **MUST** fit a suitably rated fuse or breaker between the red wire and the battery's positive terminal.
- Refer to the inline fuse ratings provided in the product's documentation.
- If you need to extend the length of the power cable, ensure you use suitably rated cable and that sufficient power (12 V dc) is available at the **SeaTalk^{ng}** backbone's power connection.

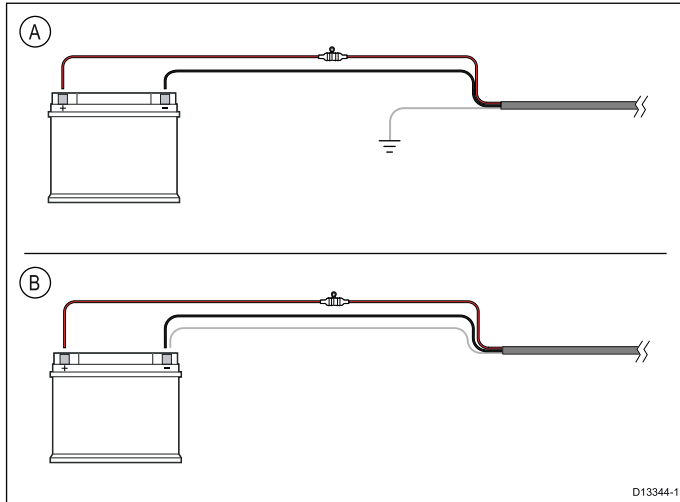

A	Battery connection scenario A: suitable for a vessel with a common RF ground point. In this scenario, if your product's power cable is supplied with a separate drain wire then it should be connected to the vessel's common ground point.
B	Battery connection scenario B: suitable for a vessel without a common grounding point. In this case, if your product's power cable is supplied with a separate drain wire then it should be connected directly to the battery's negative terminal.

Implementation — connection to distribution panel

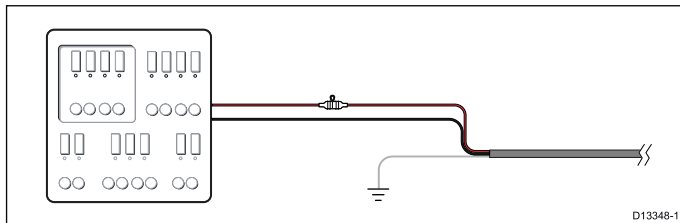

- Alternatively, the **SeaTalk^{ng}** power cable may be connected to a suitable breaker or switch on the vessel's distribution panel or factory-fitted power distribution point.
- The distribution point should be fed from the vessel's primary power source by 8 AWG (8.36 mm²) cable.
- Ideally, all equipment should be wired to individual suitably-rated thermal breakers or fuses, with appropriate circuit protection. Where this is not possible and more than 1 item of equipment shares a breaker, use individual in-line fuses for each power circuit to provide the necessary protection.
- In all cases, observe the recommended breaker / fuse ratings provided in the product's documentation.

- If you need to extend the length of the power cable, ensure you use suitably rated cable and that sufficient power (12 V dc) is available at the **SeaTalk^{ng}** backbone's power connection.

Important: Be aware that the suitable fuse rating for the thermal breaker or fuse is dependent on the number of devices you are connecting.

More information

Raymarine recommends that best practice is observed in all vessel electrical installations, as detailed in the following standards:

- BMEA Code of Practice for Electrical and Electronic Installations in Boats
- NMEA 0400 Installation Standard
- ABYC E-11 AC & DC Electrical Systems on Boats
- ABYC A-31 Battery chargers and Inverters
- ABYC TE-4 Lightning Protection

Sharing a breaker

Where more than 1 piece of equipment shares a breaker you must provide protection for the individual circuits. E.g. by connecting an in-line fuse for each power circuit.

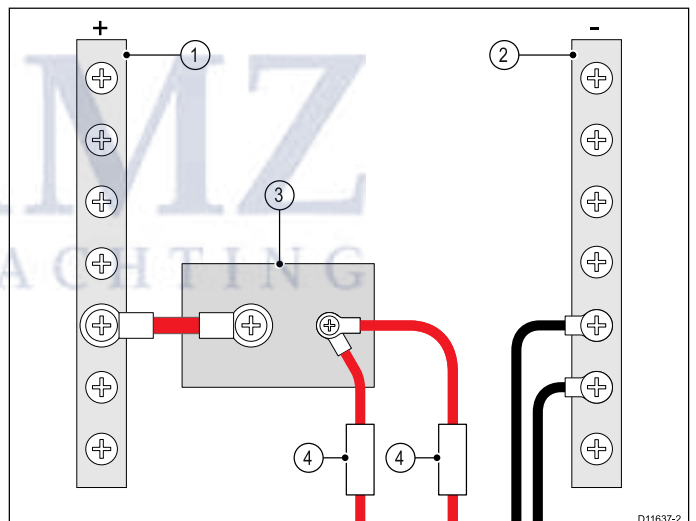

1	Positive (+) bar
2	Negative (-) bar
3	Circuit breaker
4	Fuse

Where possible, connect individual items of equipment to individual circuit breakers. Where this is not possible, use individual in-line fuses to provide the necessary protection.

 **Warning: Product grounding**
Before applying power to this product, ensure it has been correctly grounded, in accordance with the instructions provided.

 **Warning: Positive ground systems**
Do not connect this unit to a system which has positive grounding.

4.4 Cable ferrite installation

Your product is supplied with a cable ferrite. To ensure EMC Compliance, the supplied ferrite must be fitted to the cable according to the following instructions.

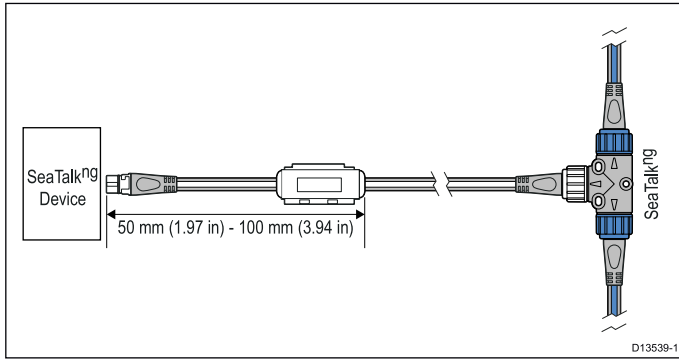

1. The ferrite must be fitted to the end of the cable closest to the device.
2. The ferrite must be fitted at the distance specified in the illustration above.
3. Ensure a tight and secure fit so that the ferrite will not move up or down the cable.

4.5 SeaTalkng® connection

The unit connects as part of a **SeaTalkng** network.

Example: SeaTalkng® system with Evolution autopilot and iTC-5

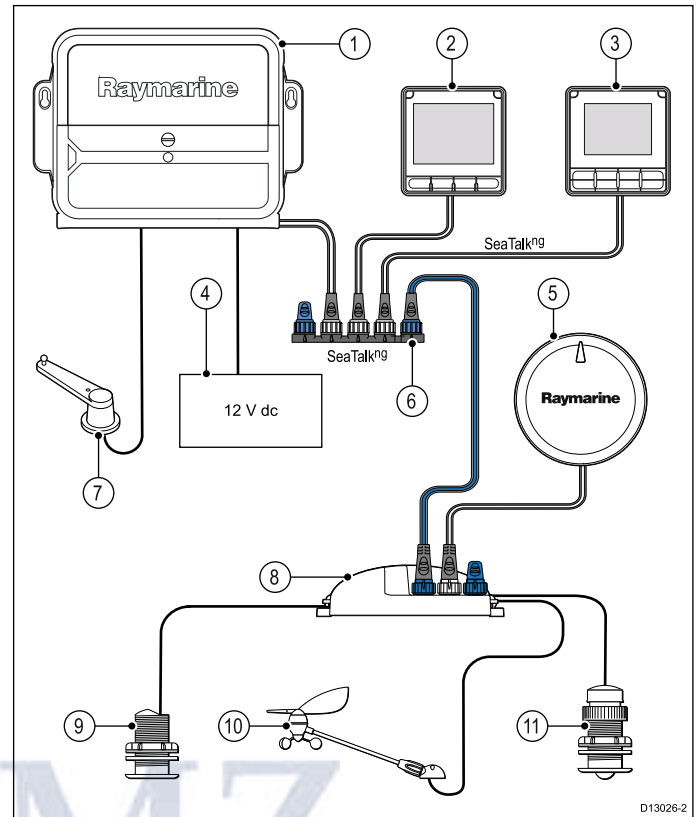

1	ACU unit
2	i70s Multifunction instrument display
3	p70s / p70Rs Pilot controller (p70s shown)
4	Vessel's 12 V dc power supply
5	EV unit
6	SeaTalkng 5-way connector
7	Rudder reference transducer
8	iTC-5 converter
9	Depth transducer
10	Wind transducer
11	Speed transducer

Note: In the above example if an **ACU-100** were used, the **SeaTalkng** network would require a dedicated 12 V dc power supply because the **ACU-100** does not supply power to the **SeaTalkng** network.

Example: SeaTalkng® system with SPX SmartPilot and transducer pods

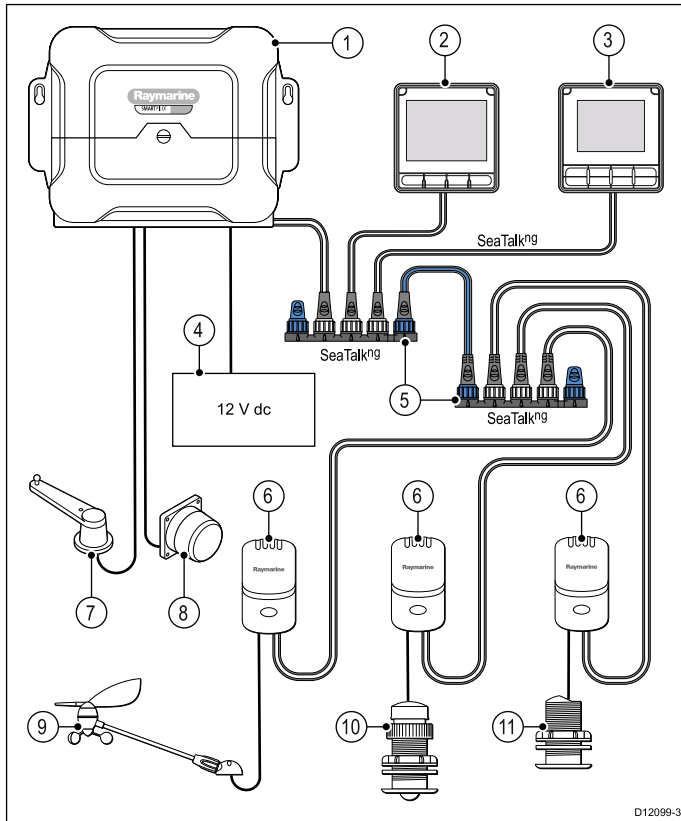

D12099-3

Item	Description
1	SPX (supplying 12 V dc to the SeaTalkng network.)
2	i70s Multifunction instrument displays
3	p70s / p70Rs Pilot controller (p70s shown)
4	Vessel's 12 V dc power supply
5	SeaTalkng 5-way connector
6	Transducer pods
7	Rudder reference transducer
8	Fluxgate compass
9	Wind transducer
10	Speed transducer
11	Depth transducer

4.6 NMEA 2000 connection

You can:

- use your **SeaTalkng®** backbone and connect **NMEA 2000** devices using a spur, or
- connect the unit to a **DeviceNet** spur into an existing **NMEA 2000** backbone.

Important: 2 terminated backbones cannot be connected together, unless you have an isolation gateway between the backbones.

Connecting NMEA 2000 equipment to the SeaTalkng® backbone

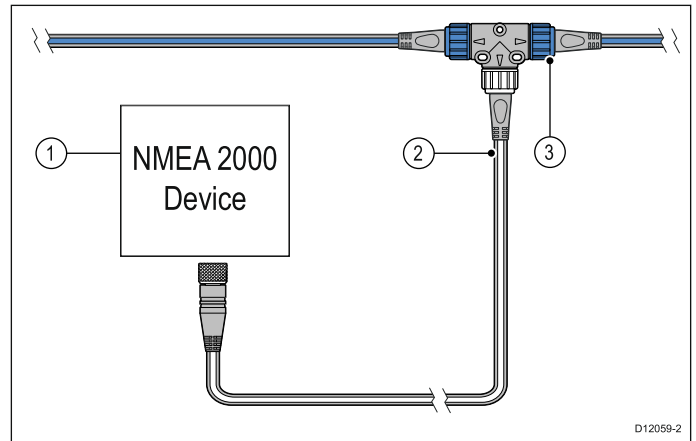

D12059-2

1. **NMEA 2000** device
2. **SeaTalkng®** to **DeviceNet** adaptor cable
3. **SeaTalkng®** backbone.

Connecting the unit to an existing NMEA 2000 (DeviceNet) backbone

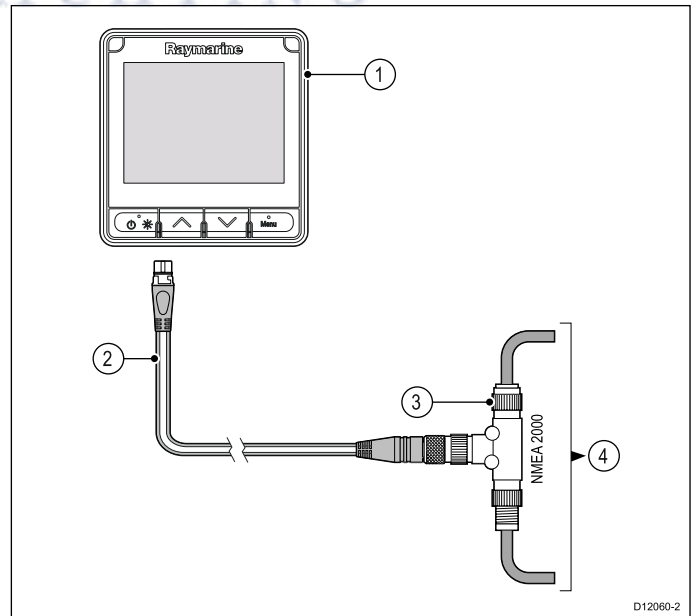

D12060-2

1. **SeaTalkng®** device e.g. **i70s / p70s / p70Rs** (**i70s** shown)
2. **SeaTalkng®** to **DeviceNet** adaptor cable
3. **DeviceNet** T-piece
4. **NMEA 2000** backbone

4.7 SeaTalk connection

Connections to an existing **SeaTalk** system must be made using a **SeaTalk** to **SeaTalk^{ng}** adaptor cable.

Basic SeaTalk system example

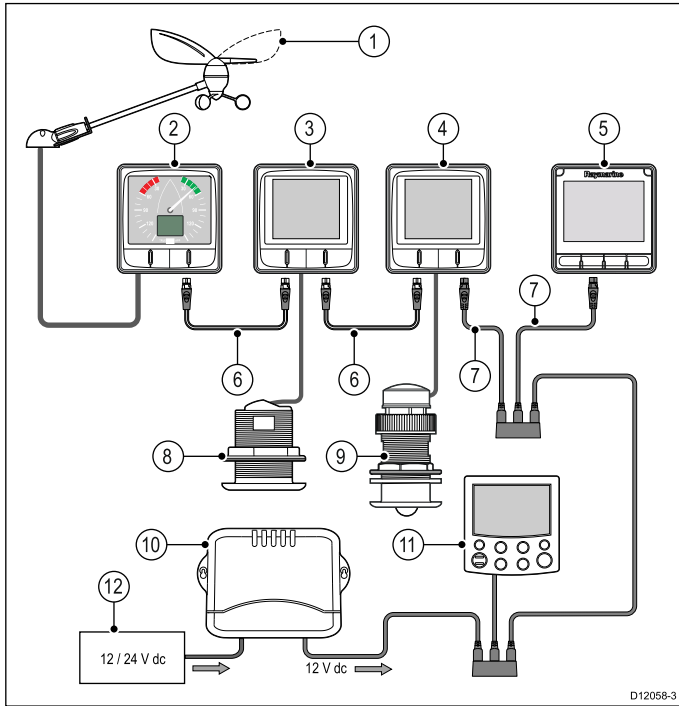

1	Wind vane transducer
2	i60 Wind (SeaTalk^{ng} Wind instrument)
3	i50 Depth (SeaTalk^{ng} Depth instrument)
4	i50 Depth (SeaTalk^{ng} Speed instrument)
5	i70s (SeaTalk^{ng} Multifunctional instrument display)
6	SeaTalk^{ng} spur cables
7	SeaTalk to SeaTalk^{ng} adaptor cables
8	Speed transducer
9	Depth transducer
10	SeaTalk Course computer (providing 12 V dc power to SeaTalk network.)
11	ST6002 (SeaTalk pilot controller)
12	12 / 24 V dc power supply

SeaTalk power protection

The power supply must be protected by a 5 A fuse or a circuit breaker providing equivalent protection.

Raymarine recommends that the power is connected to a **SeaTalk** system in such a way that the current drawn on each side of the power connection point is equal.

4.8 Transducer connections

iTC-5 connection

For details on connecting an **iTC-5** to the **SeaTalk^{ng}** backbone and connecting transducers to the **iTC-5**, refer to the documentation provided with your **iTC-5**.

Transducer pod connection

Transducer pods are available for wind, depth and speed transducers. For detailed installation instructions, refer to documentation supplied with your pod.

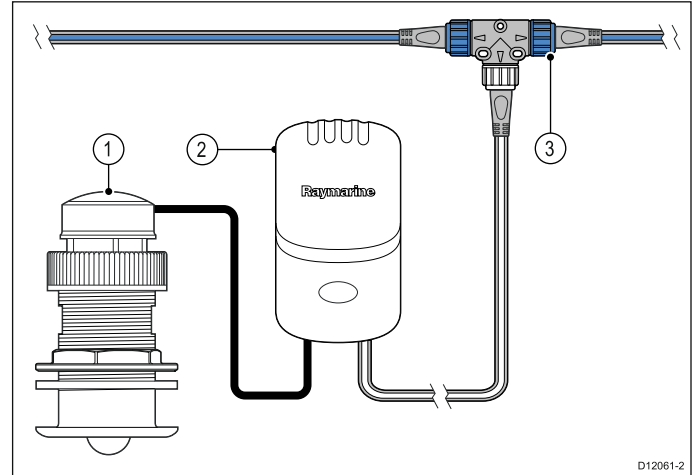

Item	Description
1	Speed and Temperature transducer
2	Speed pod
3	SeaTalk^{ng} T-Piece connector

1. Connect the transducer to the pod, the pod terminals are color-coded, ensure that each wire is connected to the corresponding terminal.
2. Connect the pod to the **SeaTalk^{ng}** backbone using a **SeaTalk^{ng}** spur cable and T-piece. Pods must be located no further than 400 mm (15.75 in.) from the connection point on the backbone



Chapter 5: Mounting

Chapter contents

- 5.1 Bezel removal on page 30
- 5.2 Removing the keypad on page 30
- 5.3 Mounting on page 31



5.1 Bezel removal

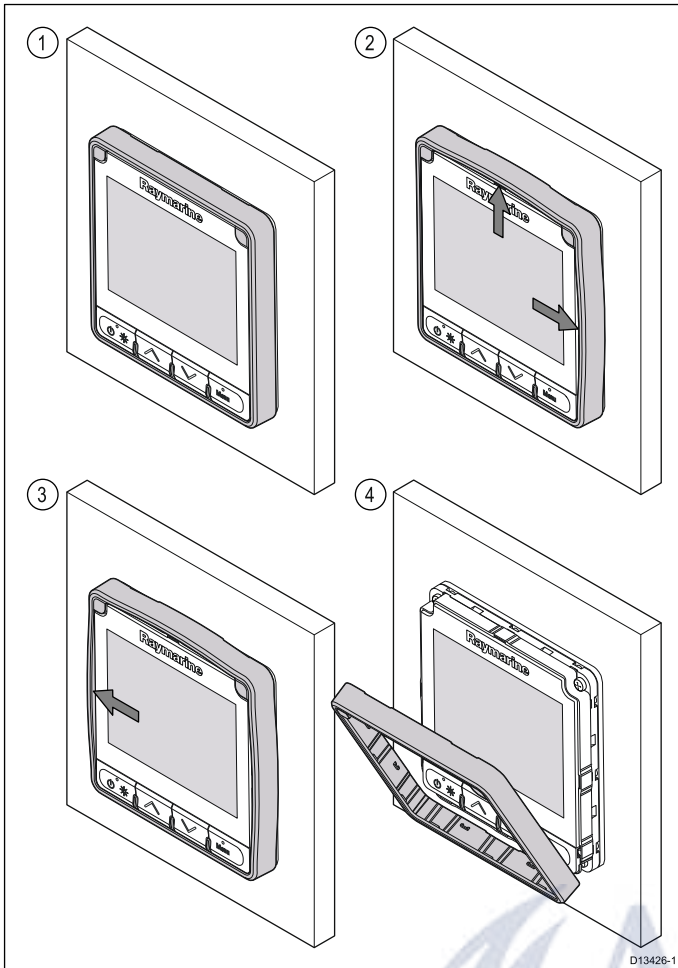

Removing the bezel

Note: Take care when removing the bezel. Do not use any tools to lever the bezel, doing so may cause damage.

1. Using your fingers pull the bezel away from the unit at the top and on one side.
You should hear a click as each side is released.
2. Now pull the bezel away from the unit on the opposite side.
The bezel can now be pulled away from the unit.

5.2 Removing the keypad

To remove the keypad from the unit follow the steps below.

- **Care Point** — Take care not to bend the keypad as this may prevent the keypad from fitting correctly.

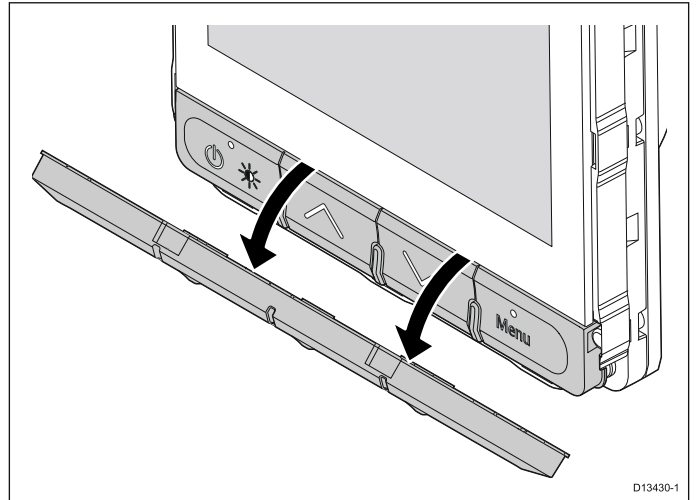

1. Remove the Front bezel.
2. Using your fingers, grip the top edge of the keypad and pull it down and away from the unit.

5.3 Mounting

Pre-mounting check

The product is designed to be surface mounted. Before mounting the unit, ensure you have:

- Selected a suitable location.
- Identified the cable connections and route that the cables will take.
- Detached the front bezel.
- Remove the keypad mat.

Mounting diagram

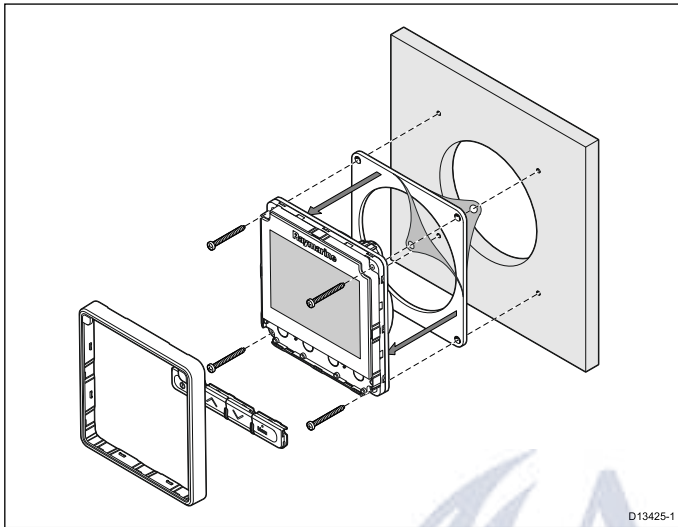

Mounting instructions

1. Check the selected location for the unit, a clear, flat area with suitable clearance behind the panel is required.
2. Fix the mounting template supplied with the product, to the selected location, using masking or self adhesive tape.
3. If possible use an appropriate size hole cutter and cut out the centre hole cut out area as indicated on the mounting template, or
4. Using a suitable drill bit, make pilot holes in each corner of the cut out area and using a jigsaw cut along the inside edge of the cut out line.
5. Ensure that the unit fits into the removed area and then file around the cut edge until smooth.
6. Drill any required holes as indicated on the mounting template for the mounting fixings.
7. Peel the backing off of the supplied gasket and place the adhesive side of the gasket onto the display unit and press firmly onto the flange.
8. Connect the relevant cables to the unit.
9. Slide the unit into place and secure using the fixings provided.
10. Fit keypad mat and front bezel.

Note: Drill, tap size and tightening torques are dependant upon the material type and thickness of the mounting surface.

Note: The supplied gasket provides a seal between the unit and a suitably flat and stiff mounting surface or binnacle. The gasket should be used in all installations. It may also be necessary to use a marine-grade sealant if the mounting surface or binnacle is not entirely flat and stiff or has a rough surface finish.

Refitting the keypad

The keypad is held in place by tabs, located on the top and bottom edge of the keypad. To refit the keypad correctly all of the tabs must be engaged.

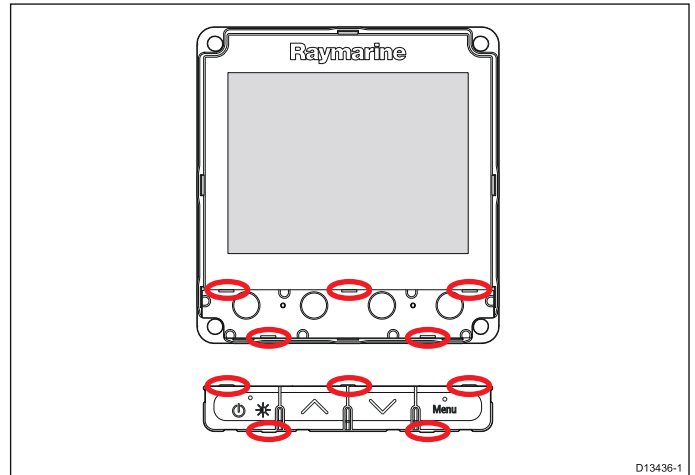

1. Tilt the top edge of the keypad forwards and insert the bottom edge into the unit, ensuring the tabs line up with their respective slots.

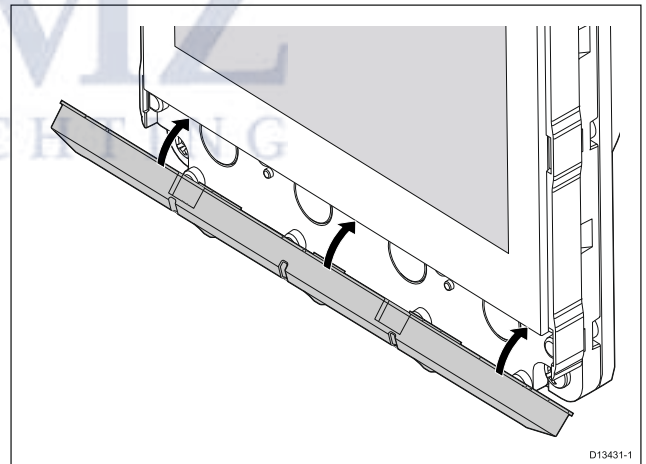

2. Push the top edge of the keypad back and up into the unit.
3. Using your fingers, apply pressure at each tab location, ensuring that the keypad tabs are fully engaged.
4. Refit the bezel.



Chapter 6: Getting started

Chapter contents

- 6.1 Controls on page 34
- 6.2 Power on page 34
- 6.3 Completing the startup wizard on page 35
- 6.4 Display settings on page 35
- 6.5 Multiple data sources (MDS) overview on page 37
- 6.6 Quick Options menu on page 38

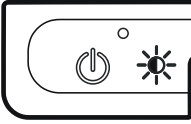
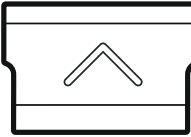
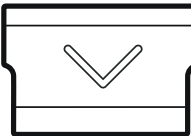
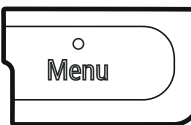

6.1 Controls

Button	Name	Function
	Power	Power on, Power off, Open brightness menu, Cancel, Back
	Up	Move up, Increase adjustment values
	Down	Move down, Decrease adjustment values
	Menu	Open menu, select, OK, Save

6.2 Power

Powering on the unit

The unit will automatically turn on with the system, unless it has previously been powered off using the **Power** button.

With the unit powered off:

1. Press and hold the **Power** button until the screen turns on (approximately 2 seconds).

Powering off the unit

1. Press and hold the **Power** button until the power count down timer reaches zero.

Note: When powered off, the unit will still draw a small amount of power from the battery, if this is a concern unplug the connector from the back of the unit.



6.3 Completing the startup wizard

When you power-up the unit for the first time or after a system reset the Startup Wizard is displayed.

The setup wizard guides your through the following basic configuration settings:

1. Language
2. Boat Type
3. Welcome

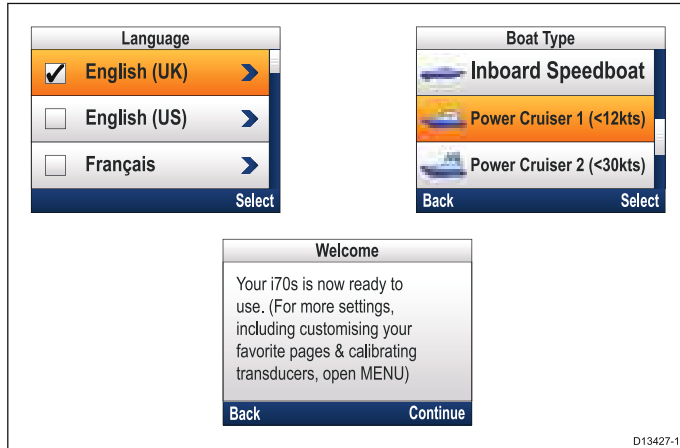

1. Using the **Up** and **Down** buttons, highlight the user interface Language that you want to use and then press the **Menu** button to confirm the selection.
2. Using the **Up** and **Down** buttons, highlight the Boat Type that you want to use and then press the **Menu** button to confirm the selection.
The Welcome page is displayed.
3. Select **Continue**.
The first of a pre-defined set of Favorite pages is displayed.

Note: The Startup Wizard may not be displayed if these settings have already been set on the system that the unit is connected to.

6.4 Display settings

Adjusting the unit's brightness

To adjust the unit's LCD brightness level, when it is not part of a Shared Brightness group follow the steps below.

1. Press the **Power** button.
The Display Brightness page is displayed.
2. Use the **Up** and **Down** buttons to adjust the brightness to the required level.
3. Select **Ok**.
The Display Brightness page will time-out after 2 seconds, saving the new brightness level.

Shared Brightness

You can set up Shared Brightness groups which enables simultaneous brightness adjustment the all units that are part of the same group.

The following products are compatible with Shared Brightness:

- **LightHouse™** powered MFDs
- **SeaTalkng®** Instrument displays and Pilot controllers

Any adjustments to the Shared Brightness level will be reflected on all units assigned to the same group.

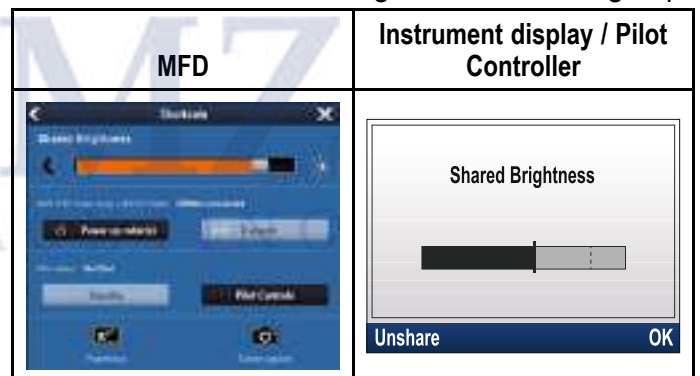

Multiple brightness groups can be configured. These groups could be used to reflect the physical location of units on your vessel. For example, the units at your helm can be set to one group, and the units on the flybridge can be set to a different group.

Shared Brightness requires:

- all units to be compatible with the Shared Brightness function (see list of compatible units above).
- the **Share brightness** setting set to On for all units in the brightness group.
- units to be assigned to Network Groups.
- all the displays in that group to be synchronized.

Assigning A Network Group

To enable the Shared Brightness and Color, unit's must be assigned to the same network group.

Compatible Instrument Displays and Pilot Controllers will also share their Color Scheme.

From the Network Group menu: (**Menu > Set-up > System Set-up > Network Group**)

1. Select the Network Group that you want to assign the unit to.

A list of network groups will be displayed:

- None (default)
- Helm 1
- Helm 2
- Cockpit
- Flybridge
- Mast
- Group 1 — Group 5

2. Select **Brightness/Color Group**.
3. Select **This Group**.
4. Select **Sync**.

The System will now synchronize all units assigned to the same group.

5. Select **OK**.
6. Carry out steps 1 to 5 on all unit's.

The location of the Shared Brightness menu on **LightHouse™** MFDs is: (**Homescreen > Customize > Display Preferences > Shared Brightness**)

Adjusting the Brightness level will now effect all units assigned to the same group.

Unsharing a unit

Instrument Displays and Pilot Controllers can be removed from the Shared Brightness.

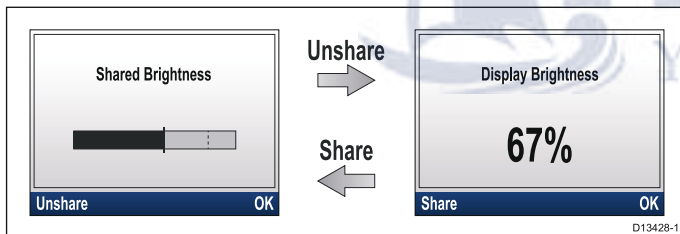

1. Press the **Power** button to display the Shared Brightness page.
2. Select **Unshare**.

Selecting **Share** from the Display Brightness page will switch back to Shared Brightness.

Changing the color scheme

From the colors menu: (**Menu > Display Settings > Colors**)

1. Select a color scheme from the list
 - Day 1
 - Day 2
 - Inverse
 - Red/Black

If the unit is part of a network group, the color scheme selected will change on all units that support color schemes and are part of the same group.

Display response

Setting the Display Response

Setting the Display Response to a low value will dampen data fluctuations to provide a more stable reading. Setting the Display Response to a high value will reduce then damping to make readings more responsive.

From the Display Settings menu: (**Menu > Display Settings**)

1. Select **Display Response**.
2. Select the data type:
 - Speed
 - Depth
 - Wind speed
 - Wind angle
 - Heading
3. Adjust the value as required.
4. Select **Save**.

6.5 Multiple data sources (MDS) overview

When a system includes multiple instances of a data source the preferred data source is selected automatically. The systems preferred source may not be your preferred source, or if you are experiencing a data conflict you can manually select your preferred data source.

MDS enables you to choose a preferred source for the following data types:

- GPS Position
- GPS Datum
- Time & Date
- Heading
- Depth
- Speed
- Wind

This exercise would usually be completed as part of the initial installation, or when new equipment is added.

For MDS to be available all products in the system that use the data sources listed above, must be MDS-compliant. The system will report any products that are NOT MDS-compliant. It may be possible to upgrade the software for these products, to make them compliant. Visit the Raymarine website (www.raymarine.com) to obtain the latest software for your products.

If MDS-compliant software is not available for the product and you do NOT want to use the systems preferred data source, you must remove any non-compliant product from the system. You should then be able to select your preferred data source.

Note: Once you have completed setting up your preferred data sources, you may be able to add the non-compliant products back into the system.

Selecting a preferred data source

From the System Set-up menu: (**Menu > Set-up > System Set-up**)

1. Select **Data Sources**.
2. Select the Data type.

The unit will now search for and display a list of all sources for the selected data type.

Depth	
<input checked="" type="checkbox"/>	Auto
<input type="checkbox"/>	00380016 STng - ACTIVE ST70 Depth Pod
<input type="checkbox"/>	00420065 STng iTC-5 Converter
Back	Select

3. Select your preferred data source, or
4. Select **Auto** to allow the system to decide.

ACTIVE is displayed next to the data source that is the current source for the data type.

6.6 Quick Options menu

The **Quick Options** menu (**Menu > Quick Options**) is a dynamic menu that displays menu items relative to the data displayed on the current Favorite page or Quick View page being viewed.

Quick options menu items

Depending on the page being displayed different quick options are available as follows:

Page displayed	Quick options available
Menu	Edit page
MOB (when MOB is active)	MOB
Maximum depth	Reset Maximum Depth
Minimum depth	Reset Minimum Depth
Maximum speed	Reset Maximum Speed
Average speed	Reset Average Speed
Trip	Reset Trip
Max. SOG	Reset Max. SOG
Ave. SOG	Reset Ave. SOG
CMG & DMG	Reset CMG & DMG
Maximum Sea Temperature	Reset Max. Sea Temperature
Minimum Sea Temperature	Reset Min. Sea Temperature
Maximum Air Temperature	Reset Max. Air Temperature
Minimum Air Temperature	Reset Min. Air Temperature
Maximum AWA	Reset Maximum. AWA
Minimum AWA	Reset Minimum. AWA
Maximum AWS	Reset Max. AWS
Minimum AWS	Reset Min. AWS
Maximum TWA	Reset Max. TWA
Minimum TWA	Reset Min. TWA
Maximum TWS	Reset Max. TWS
Minimum TWS	Reset Min. TWS
Race Timer	Start timer
	Stop timer
	Reset timer
	Adjust start times
Graph	Time scale
(View data) page	Add to favorites
AIS	View AIS targets — (Only shown if there is Heading or stable COG data available.)
	AIS range
	AIS Silent mode

Chapter 7: Transducer calibration

Chapter contents

- 7.1 Transducer types on page 40
- 7.2 Depth calibration on page 40
- 7.3 Speed calibration on page 41
- 7.4 Wind calibration on page 46
- 7.5 Rudder reference calibration on page 48
- 7.6 Compass calibration on page 49



7.1 Transducer types

The transducers listed in the table below can be calibrated using the display.

Transducer type	Connection
Depth transducers	connected via iTC-5 or Depth pod
Speed and temperature transducers	connected via iTC-5 or Speed pod
Wind transducers	connected via iTC-5 or Wind pod
Smart transducers	connected directly to SeaTalk^{ng}
Fluxgate compass	connected via iTC-5
Rudder reference	connected via iTC-5

7.2 Depth calibration

Depth Offset

Depths are measured from the transducer to the bottom, you can apply an offset value to the depth data, so that the displayed depth reading represents the depth to the bottom from either the keel (negative offset) or the waterline (positive offset).

Before attempting to set a waterline or keel offset, find out the vertical separation between the transducer and either the waterline or the bottom of your vessel's keel, as appropriate. Then set the appropriate depth offset value.

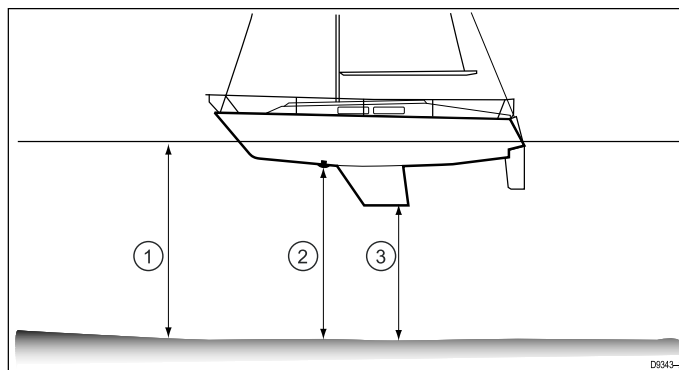

1	Waterline offset	Values greater than zero (Positive values) represent a waterline offset
2	Transducer	Zero offset represents the depth from the transducer's location
3	Keel offset	Values less than zero (Negative values) represent a keel offset

Setting the depth offset

The depth calibration consists of setting a Depth Offset that is relevant to your depth transducer's installed location.

From any favorite page:

1. Select **Menu**.
2. Select **Set-up**.
3. Select **Transducers Set-up**.
4. Select **Continue**.

The instrument display will search for and display a list of connected devices. (i.e. iTC-5, DST or transducer pod)

5. Select the device that the transducer(s) you are calibrating are connected to.

A list of available transducer data is displayed,

6. * Select **Depth**.

Note: * Step only applicable to iTC-5.

7. Select **Depth Offset**.
8. Select **Depth From:**.

A list of transducer offsets is displayed:

- Waterline
- Keel
- Transducer (default)

9. Select the location that you want depth measurements to be taken from.
After selection the Depth Offset page is displayed. If you have selected Waterline or Keel a Depth Offset must be applied.
10. Select **Offset**:
11. Use the **Up** and **Down** buttons to adjust the Depth Offset to the required value.
The offset value should be the same as the measured distance:
 - from the transducer face to the Waterline, or
 - from the transducer face to the bottom of the Keel.
12. Select **Save**.

Setting an incorrect Depth Offset could lead to your vessel running aground.

7.3 Speed calibration

Speed transducer calibration is required as transducer performance is affected by a number of variables such as transducer location, shape of the hull and water flow characteristics. The purpose of performing Speed calibration is to ensure that the speed readings at the instrument are a true indication of the vessel's actual speed.

In order to achieve accurate results, speed calibration must be carried out in calm conditions with zero tide and zero current.

Speed calibration aligns the instruments log speed (Speed Through Water) to:

- Speed Over Ground (SOG), or
- a referenced speed

Calibrating using SOG

For most installations a 1 Point Speed Calibration is all that is required.

If the 1 point calibration does not provide sufficiently accurate readings or you require a higher level of precision for your speed readings then a Speed Run Calibration can be carried out. It is advisable to carry out the Speed Run Calibration at as many speeds as possible. This is particularly important for planing vessels.

* Conventional speed transducers have a maximum of 5 calibration speeds, and smart transducers (e.g. DST800) have up to 8.

If required each calibration point can also have a calibration factor applied to further align the log speed reading across different vessel speeds.

Note: * The Speed Run Calibration cannot be performed when the transducer is connected to a Speed Pod.

Calibrating without SOG

For most installations a 1 Point Speed Calibration is all that is required. The calibration must be performed using a way of estimating actual vessel speed and adjusting the displayed reading so that the log speed matches the your estimated speed.

If you do not have SOG data available then the Speed Run Calibration cannot be performed.

If required, further calibration points can be added and a calibration factor can be applied to further align the log speed with actual vessel speed.

	iTC-5		Smart (DST)		Speed pod	
	SOG	No SOG	SOG	No SOG	SOG	No SOG
1 point speed calibration	✓	✓	✓	✓	✓	✓
Speed run calibration	✓	✗	✓	✗	✗	✗
Manual calibration	✓	✓	✓	✓	✓	✓

1 Point Speed Calibration

For most installations a 1 Point Speed Calibration is all that is required.

Prerequisites:

- For best results SOG data should be available, or an alternative method of estimating vessel speed must be used (e.g. vessel speed can be estimated using [Nautical Measured Mile Markers](#) or similar landmarks of a known distance apart).
- You will need to be underway, with sufficient space to maneuver unhindered.
- In order to achieve accurate results, water conditions must be calm with zero tide and zero current.

From a favorite page:

1. Select **Menu**.
2. Select **Set-up**.
3. Select **Transducers Set-up**.
4. Select **Continue**.

The instrument display will search for and display a list of connected devices. (i.e. iTC-5, DST or transducer pod)

5. Select the device that the transducer(s) you are calibrating are connected to.

A list of available transducer data is displayed,

6. * Select **Speed**.

Note: * Step only applicable to iTC-5.

7. Select **Speed Calibration**.
8. Select **Adjust speed up/down**.

The 1 Point Speed Calibration page is displayed.

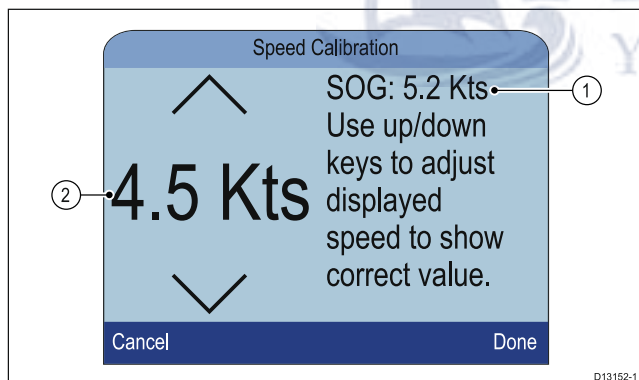

1. SOG speed reading
2. Current speed reading

If SOG is not available then the SOG value will display dashes.

9. Accelerate your vessel to a steady, typical cruising speed.
10. Use the **Up** and **Down** buttons to adjust the current speed reading so that it matches the SOG reading or matches your estimated speed.
11. Select **Done** when both values are the same. The calibration complete page is displayed.
12. Select **Ok**.

If you experience significant deviation between SOG and log speed readings at different vessel speeds then a Speed Run Calibration should be performed. Refer to the [Performing a Speed Run Calibration using SOG](#) section for details.

Nautical measured mile markers

When neither SOG data or any other reliable means of estimating Speed Through the Water (STW) is available, Nautical Measured Mile Markers can be used to help calibrate Log Speed. Nautical measured mile markers are identified by two pairs of posts or towers. The distance between each pair of markers is 1 nautical mile.

Each marker in a pair is separated by distance and elevation from its partner. The front marker is closer to the water and shorter than the marker behind it.

Markers — side view

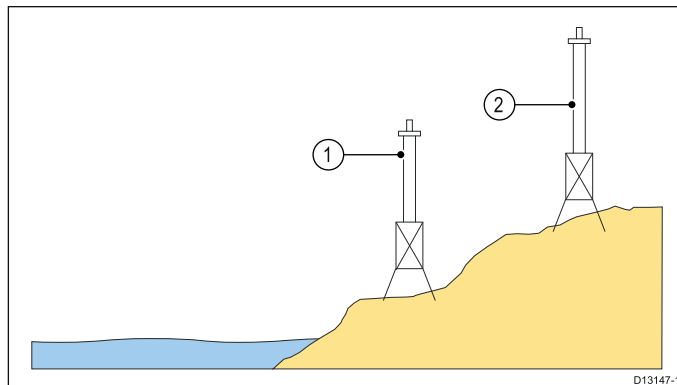

1. Front marker
2. Rear marker

When the 2 markers appear vertically aligned the vessel is on the correct range line to begin a measured mile run.

Marker alignment

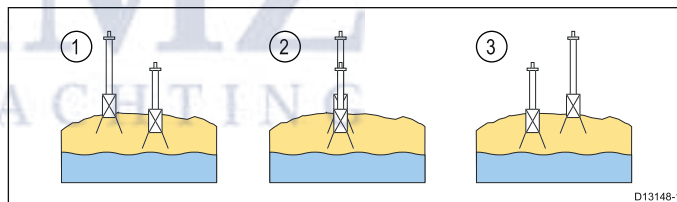

1. Left of range line
2. On range line
3. Right of range line

The vessel should already be at top speed and as the first pair of markers appear aligned a stopwatch should be started, when the vessel passes the second pair of aligned markers the stopwatch is stopped.

Measuring a nautical mile

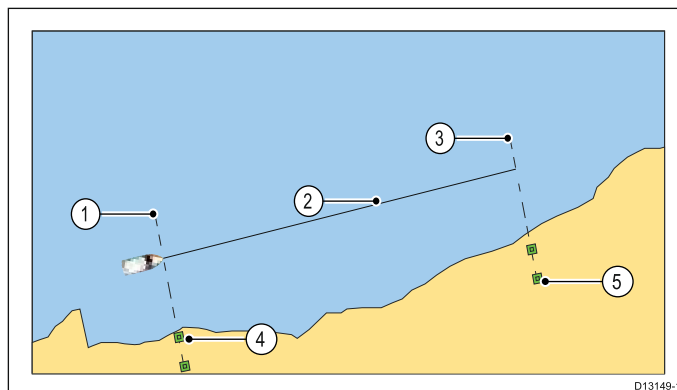

1. Starting point (start stopwatch)
2. Measured mile

3. End point (stop stopwatch)
4. First pair of markers
5. Second pair of markers

To provide a more accurate reading the vessel should make between 4 to 6 runs in both directions to allow for tide and wind conditions. The average of the time taken over all runs should be used to calculate Log Speed.

The vessel speed can then be worked out by taking the distance travelled (1 nautical mile) and dividing it by the average time taken to perform the run. The resulting calculation is your average speed in knots.

Performing a Speed Run Calibration using SOG

If a higher level of precision is required than that achieved with the 1 Point Speed Calibration procedure, a Speed Run Calibration should be performed. The Speed Run Calibration will ensure that the Log Speed reading is accurate over the vessel's full speed range.

Prerequisites:

- SOG data must be available.
- You will need to be underway, with sufficient space to maneuver unhindered.
- In order to achieve accurate results, water conditions must be calm with zero tide and zero current.

Note: Speed Run Calibration is not available when connected to a Speed Pod.

The steps below detail the method of calibrating:

- speed transducers connected via an iTC-5
- the speed element of a smart transducer connected directly to the SeaTalk^{ng} network.

From a favorite page:

1. Select **Menu**.
2. Select **Set-up**.
3. Select **Transducers Set-up**.
4. Select **Continue**.

The instrument display will search for and display a list of connected devices. (i.e. iTC-5, DST or transducer pod)

5. Select the device that the transducer(s) you are calibrating are connected to.

A list of available transducer data is displayed,

6. * Select **Speed**.

Note: * Step only applicable to iTC-5.

7. Select **Speed Calibration**.
8. Select **New cal using SOG**.

You will need to add calibration points at a range of speeds spanning the full speed range of the vessel. Conventional transducers can have up to 5 calibration points and smart transducers can have up to 8. Ideally the calibration points should be taken at regular increments throughout the speed range with the last calibration point being close to the vessel's top speed.

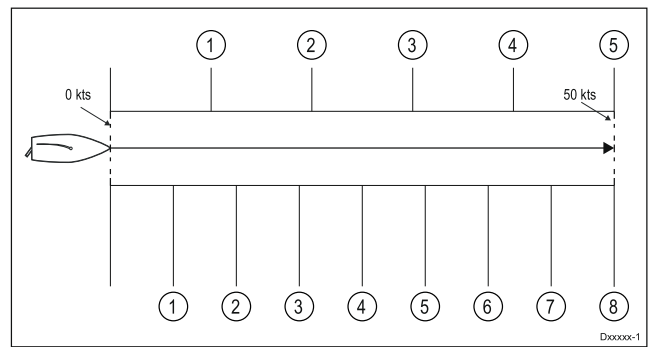

With the Speed Transducer connected to a Speed Pod the 5 calibration points are fixed in sequence at 2, 4, 8, 16 and 32 knots. When adding calibration points during the Speed Run Calibration ensure vessel speed is as close to the fixed calibration point speeds as possible, as the calibration factor applied will be the difference between the actual vessel speed and the fixed calibration point speed.

9. Select **Start**.
10. Ensure the vessel's speed is steady at your first calibration point speed and select **Add**.
11. Repeat step 10 for all remaining calibration points, ensuring that the calibration points are equally spaced throughout your vessel's speed range from stationary to top speed. Once all calibration points have been successfully added the Calibration complete message is displayed.
12. Select **Ok**.

Calibration Table

By default Speed Transducers include a default set of calibration points which are overwritten during the normal speed calibration process. The calibration points are stored in the Calibration Table. The Calibration Table can be accessed from the Advanced Menu.

From the Advanced Menu you can:

- View the existing Calibration Table
- Adjust the existing calibration points (Add, Edit or Delete calibration points)
- Enter a new Calibration Table
- Check Log Speed against SOG
- Reset the Calibration Table to factory defaults

Viewing the calibration Table

Calibration points are stored in the Calibration Table.

From a favorite page:

1. Select **Menu**.
2. Select **Set-up**.
3. Select **Transducers Set-up**.
4. Select **Continue**.

The instrument display will search for and display a list of connected devices. (i.e. iTC-5, DST or transducer pod)

5. Select the device that the transducer(s) you are calibrating are connected to.

A list of available transducer data is displayed,

6. * Select **Speed**.

Note: * Step only applicable to iTC-5.

7. Select **Speed Calibration**.
8. Select **Advanced**.
9. Select **View cal table**.

The Calibration Table is displayed.

Uncal.	Factor	Calibrated
2.0Kts	x1.00	2.0Kts
4.0Kts	x1.00	4.0Kts
8.0Kts	x1.00	8.0Kts
Back		

PaddleWheel	Prev.	New
0.6 Hz	0.6 Kts	--
5.1 Hz	1.8 Kts	--
11.9 Hz	3.4 Kts	--
Back		

1. Speed transducer connected via iTC-5 or speed pod.
 2. Smart DST transducer connected directly to SeaTalk^{ng}.
10. Use the **Up** and **Down** buttons to scroll up and down through the table.
 11. Select **Back** to return to the Advanced Menu.

Checking speed

The current speed can be checked at any time from the Advanced Menu.

From the Advanced Menu:

1. Select **Check speed**.

The Check Speed page is displayed:

Speed	
Speed	7.5 Kts
SOG	8.0 Kts
OK	

The Check Speed page can also be accessed from the Edit calibration options menu: **Advanced > Adjust cal table > Start > Options > Check speed**.

Manually working out a Calibration Factor

New Calibration Factors can be worked out manually following the steps below.

- You will need to be underway, with sufficient space to maneuver unhindered.
 - To ensure accuracy, water conditions should be calm with zero tide and zero current.
 - You will need to calibrate each calibration speed point, starting with the lowest
1. In calm conditions with zero tide and zero current, run your vessel at a steady speed, approximately that of the selected calibration speed, over a measured distance.
Make a note of:
 - The measured distance in nautical miles

- The current speed value in knots
- The time in minutes it takes to cover the measured distance

2. Calculate the actual speed over the measured distance using the calculation: (Speed = (60 x Distance) / Time) The '60' is used to ensure the calculation is in minutes rather than hours or tenths of an hour.

e.g. Distance = 14 nautical miles, Time = 105 minutes (1 hour 45 minutes) so:

- $S = (60 \times D) / T$
- $S = (60 \times 14) / 105$
- $S = 840 / 105$
- $S = 8 \text{ Kts}$

3. If the calculated speed is:

- The same as the current speed, (noted during the Speed Run Calibration) then the calibration is correct at this speed so no action is required.
- Not the same as the current speed. Calculate a new, corrected Calibration Factor, as follows:
e.g. if actual speed equals 8 kts, indicated speed was 7.5 kts and the old Calibration Factor was 1.4 then:

- new cal factor = actual speed x old factor / indicated speed
- new cal factor = $8 \times 1.4 / 7.5$
- new cal factor = $11.2 / 7.5$
- new cal factor = 1.49

Adding a Calibration Point

Calibration Points can be manually added to the Calibration Table. The amount of Calibration Points that can be stored is determined by the type of speed transducer and method of connection.

From the Transducer found menu: **Menu > Set-up > Transducer set-up > Continue** :

1. Select the device that the transducer(s) you are calibrating are connected to.

A list of available transducer data is displayed,

2. * Select **Speed**.

Note: * Step only applicable to iTC-5.

3. Select **Speed Calibration**.
4. Select **Advanced**.
5. Select **Adjust Calibration**.
6. Select **Start**.

The current Calibration Table is displayed.

7. Select the relevant Calibration Point from the table.
8. Select **Options**.
9. Select **Add cal point**.
10. Use the **Up** and **Down** buttons to adjust the displayed Log Speed to match SOG, if available or to match your estimated actual speed.
11. Select **Add**.
12. Select **Ok**.

13. Repeat steps 7 to 11 for each Calibration Point you want to add.

The more Calibration Points the higher the accuracy of Log Speed.

Note: If the text appears red then the new reading deviates too far from the stored reading. You will need to add a Calibration Point closer to the stored reading a try again.

Editing a Calibration Point

Existing Calibration Points can be manually edited.

From the Advanced Menu:

1. Select **Adjust cal table**.
2. Select **Start**.
3. Highlight the relevant Calibration Point from the table.
4. Select **Options**.
5. Select **Edit cal point**.

The Calibration Point Adjustment page is displayed.

6. Use the **Up** and **Down** buttons to adjust the Calibration Factor for the selected speed to match your new Calibration Factor.
7. Select **Done** to return to the Calibration Table.
8. Repeat steps 4 to 7 for all Calibration Points that require adjustment.
9. Select **Finish** when all of the required Calibration Points have been adjusted.

Deleting a Calibration Point

Calibration Points can be deleted from the Calibration Table.

From the Adjust cal table menu:

1. Select **Start**.
2. Highlight the Calibration Point you want to delete.
3. Select **Options**.
4. Select **Yes** to delete.

The Calibration Point is deleted from the Calibration Table.

Resetting the Calibration Table

The Calibration Table can be reset to factory default values by following the steps below:

From the Advanced Menu:

1. Select **Reset to defaults**.
2. Select **Yes**.
3. Select **Ok**.

The Calibration Table is reset to factory default values.

Entering a new Calibration Table

A new Calibration Table can be added manually. The new Calibration Table replaces the existing table which is deleted. This is useful when you have been provided a specific calibration table for your hull type.

Note: You will need to work out your Calibration Factors for each Calibration Point before you can create the new Calibration Table.

From the Advanced Menu:

1. Select **Enter new cal table**.
2. Select **Start**.

All existing Calibration Points are deleted and you will be prompted to enter new Calibration Points.

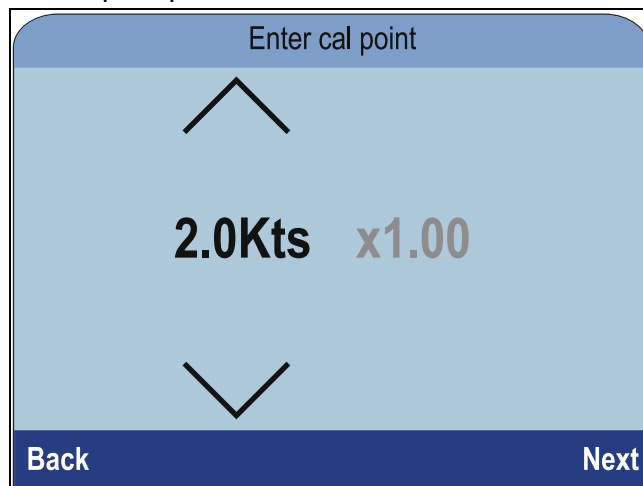

3. Use the **Up** and **Down** buttons to select the desired speed that you want to add a Calibration Point for.
4. Select **Next**.
5. Use the **Up** and **Down** buttons to adjust the Calibration Factor to the correct value.
6. Select **Done**.
7. Select **Add** to add the next Calibration Point.
8. Repeat steps 3 to 7 for all Calibration Points you want to add.
9. Select **Finish** when all Calibration Points have been added.
10. Select **OK**.

Calibrating Water Temperature

The Water Temperature reading can be calibrated as follows:

You will need a suitable thermometer to measure the Water Temperature.

From a favorite page:

1. Select **Menu**.
2. Select **Set-up**.
3. Select **Transducers Set-up**.
4. Select **Continue**.

The instrument display will search for and display a list of connected devices. (i.e. iTC-5, DST or transducer pod)

5. Select the device that the transducer(s) you are calibrating are connected to.

A list of available transducer data is displayed,

6. * Select **Speed**.

Note: * Step only applicable to iTC-5.

7. Select **Current Temperature** option.
8. Use a suitable thermometer to measure the actual water temperature.
9. Use the **Up** and **Down** buttons to match the displayed Water Temperature to the actual Water Temperature measured by the thermometer.
10. Select **Save** to save the setting.

7.4 Wind calibration

Calibrating wind

- You will need to be underway, with sufficient space to turn in a large slow circle unhindered.
- Conditions should be calm (i.e. a slight sea) and a steady breeze. Try to ensure the vessel is not rolling or pitching too much.

From a favorite page:

1. Select **Menu**.
2. Select **Set-up**.
3. Select **Transducers Set-up**.
4. Select **Continue**.

The instrument display will search for and display a list of connected devices. (i.e. iTC-5, DST or transducer pod)

5. Select the device that the transducer(s) you are calibrating are connected to.
A list of available transducer data is displayed,
6. * Select **Wind**.

Note: * Step only applicable to iTC-5.

7. Select **Calibrate Wind Xdcr**.
8. Keep the vessel speed below 2 kts and observing the screen, start to turn the vessel in a circle, then select **Start**.
9. Continue turning the vessel in circles until **Complete** is displayed on-screen.

If your rate of turn is too fast during calibration, a **Slow Down** message is displayed. If this happens, reduce your rate of turn this can be achieved by slowing down and / or steering in a wider circle.

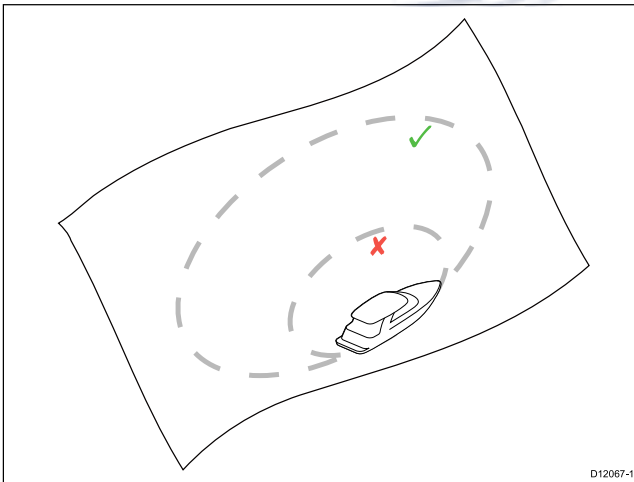

10. Select **Continue**.
11. If required use the **UP** and **DOWN** buttons to manually adjust the vane offset.
12. Press **SELECT** to complete the calibration process and save the settings.

If required you can manually adjust each part of the calibration steps by selecting the relevant options from the **Wind** menu.

Aligning the wind transducer

- You will need to be underway, with sufficient space to turn in a large slow circle unhindered.

- Conditions should be calm (i.e. a slight sea) and a steady breeze. Try to ensure the vessel is not rolling or pitching too much.

From the list of transducers found:

1. Select the device that the transducer(s) you are calibrating are connected to.
A list of available transducer data is displayed,
2. * Select **Wind**.

Note: * Step only applicable to iTC-5.

3. Select **Align Wind Xdcr**.
4. Now steer your vessel directly into the wind and select **Continue**.

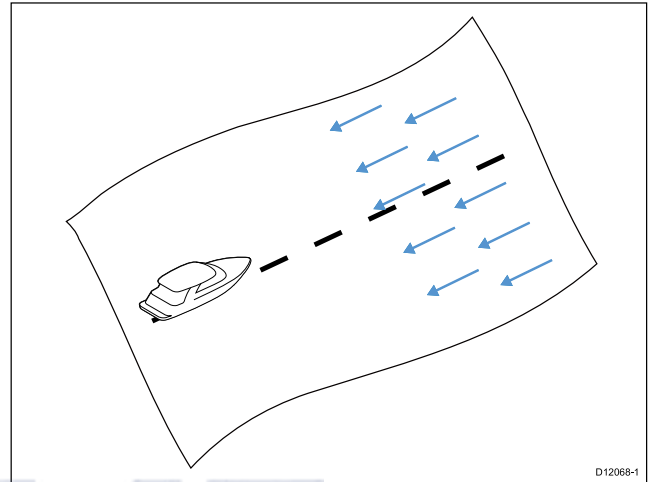

Adjusting the wind transducer

You can manually adjust the offset.

- You will need to be underway, with sufficient space to turn in a large slow circle unhindered.
- Conditions should be calm (i.e. a slight sea) and a steady breeze. Try to ensure the vessel is not rolling or pitching too much.

From the list of transducers found:

1. Steer your vessel directly into the wind

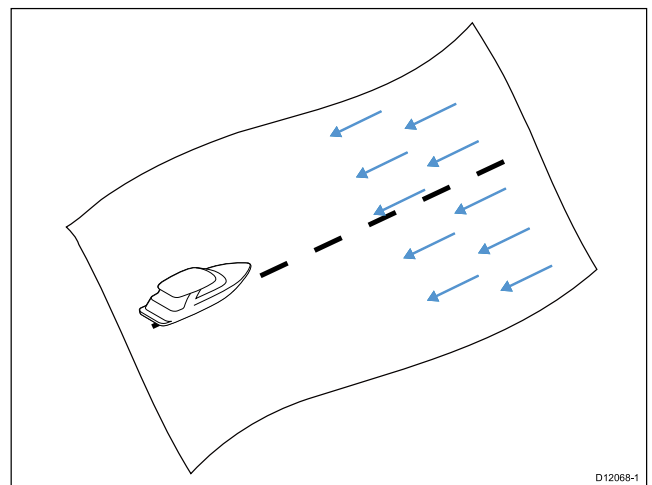

With your vessel sailing directly into the wind the Apparent Wind Angle (AWA) should be 0 degrees.

2. Select the device that the transducer(s) you are calibrating are connected to.
A list of available transducer data is displayed,
3. * Select **Wind**.

Note: * Step only applicable to iTC-5.

4. Select **Wind Xdcr Adjust**.

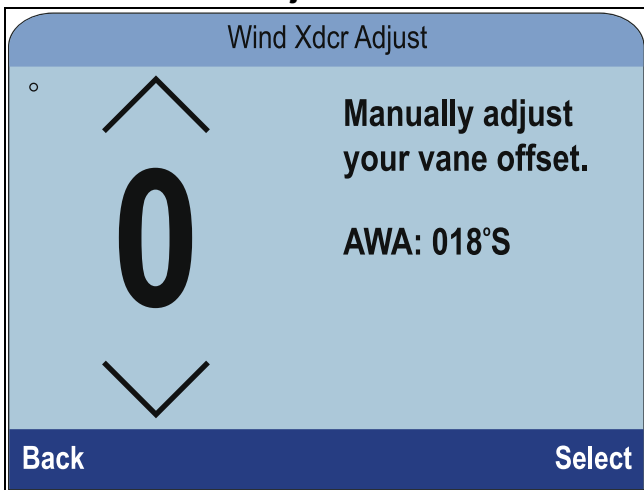

5. Use the **Up** and **Down** buttons to adjust the offset value so that the reported AWA is 0 degrees.

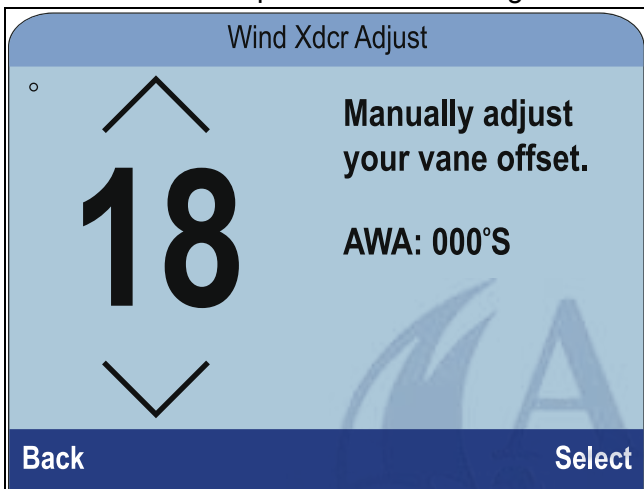

6. Select **Select**.

Adjusting apparent wind speed

To apply a Calibration Factor to the Apparent Wind Speed (AWS) reading follow the steps below.

- To apply an offset to your AWS readings an accurate reference for AWS must be used to compare the instrument's AWS reading against.
- Conditions should be calm (i.e. a slight sea) and a steady breeze. Try to ensure the vessel is not rolling or pitching too much.

From the list of transducers found:

1. Select the device that the transducer(s) you are calibrating are connected to.

A list of available transducer data is displayed,

2. * Select **Wind**.

Note: * Step only applicable to iTC-5.

3. Select **App Wind Speed**.

The AWS Calibration Factor page is displayed.

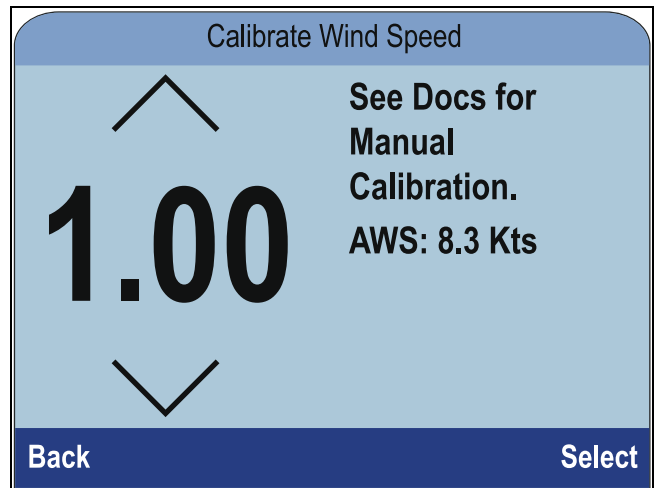

4. Use the **Up** and **Down** buttons to adjust the Calibration Factor until the AWS reading matches your referenced source of AWS.

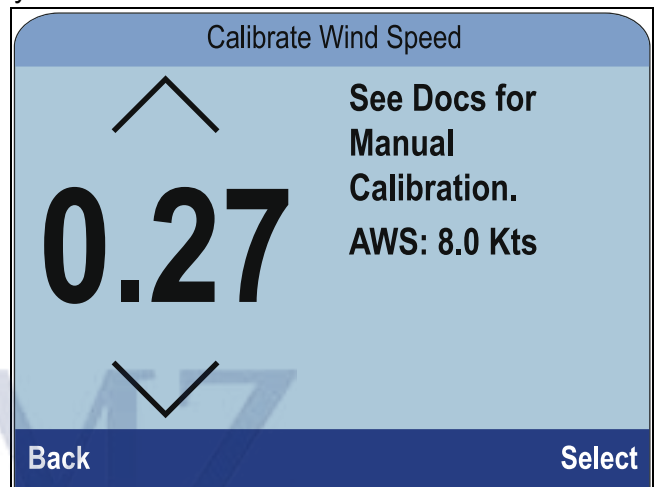

The Calibration Factor default is 1.00 the Calibration Factor can be adjusted from 0.25 to 2.00.

5. Select **Select** to save the Calibration Factor.

7.5 Rudder reference calibration

You can calibrate a rudder reference transducer that is connected to an iTC-5.

The rudder reference transducer must be connected to the rudder reference connection of the iTC-5 . Rudder reference transducers connected to an autopilot must be calibrated using the pilot controller.

Centering the Rudder

Centering the Rudder requires a method of knowing the Rudder's actual position.

From a favorite page:

1. Select **Menu**.
2. Select **Set-up**.
3. Select **Transducers Set-up**.
4. Select **Continue**.

The instrument display will search for and display a list of connected devices. (i.e. iTC-5, DST or transducer pod)

5. Select **iTC-5**.

A list of available transducer data is displayed,

6. Select **Rudder**.
7. Select **Centre Rudder**.

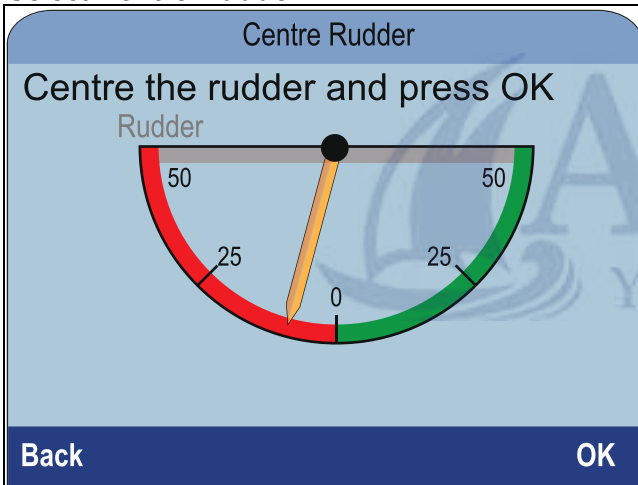

8. Turn the steering until the Rudder is centred.

The Rudder Reference has indicators on its base and on the rudder arm, ensure these marks are lined up.

9. With the Rudder centered, select **Ok**.

The pointer is zeroed on the display.

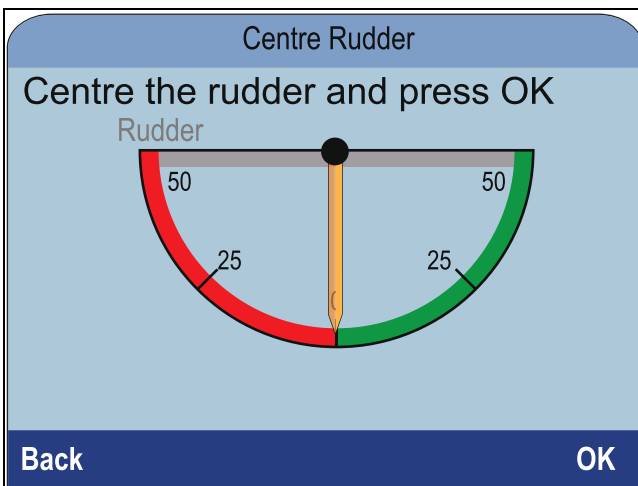

10. Select **Back** to return to the Rudder Calibration Menu.

Adjusting the Rudder Angle

You can manually adjust the Rudder Angle.

Manual adjustment of the Rudder Angle requires a method of knowing the Rudder's actual position.

From the transducers found page:

1. Ensure that the rudder is centered
2. Select **iTC-5**.
A list of available transducer data is displayed.
3. Select **Rudder**.
4. Select **Adjust Rudder Angle**.

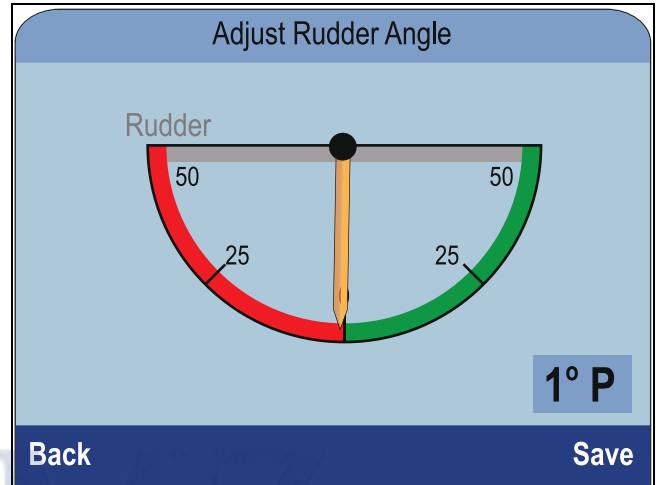

5. Use the **Up** and **Down** buttons to adjust the pointer so that the pointer and the reported Rudder Angles are both zero.
6. Select **Save**.

Inverting the Rudder

If the display's Rudder Pointer moves in the opposite direction (i.e. when you turn the Rudder starboard the pointer moves port) this can be corrected by inverting the Rudder.

From the transducers found page:

1. Ensure that the rudder is centred.
2. Select **iTC-5**.
A list of available transducer data is displayed.
3. Select **Rudder**.
4. Select **Invert Rudder Angle**.
5. If the pointer is pointed in the opposite direction than that expected, select **Invert** .

7.6 Compass calibration

You can calibrate a Fluxgate Compass that is connected to an iTC-5.

The compass must be connected to the compass connection of the iTC-5. Compasses connected to an autopilot must be calibrated using a Pilot Controller.

Swinging the Compass

You will need to turn your vessel in slow circles while the system automatically makes adjustments to account for Compass Deviation. Each 360-degree circle should take no less than two minutes, and you should complete at least two circles.

It is recommended that a second instrument display or MFD is used to display heading data, whilst performing the Compass Swing.

From a favorite page:

1. Select **Menu**.
2. Select **Set-up**.
3. Select **Transducers Set-up**.
4. Select **Continue**.

The instrument display will search for and display a list of connected devices. (i.e. iTC-5, DST or transducer pod)

5. Select **iTC-5**.

A list of available transducer data is displayed,

6. Select **Compass**.
7. Select **Swing Compass**.

8. Start moving vessel in slow even circles, then press **Start**.
9. Keep vessel speed to below 2 knots. Watch the display to ensure your turn rate is not too fast. If the message 'Slow Down — turn rate too fast' is displayed reduce your rate of turn, this can be achieved by slowing down and / or steering in a wider circle.

If the 'Slow Down — turn rate too fast' message is displayed the current circle will have to be repeated.

When the Compass has been calibrated, a message will be displayed showing the detected Compass Deviation.

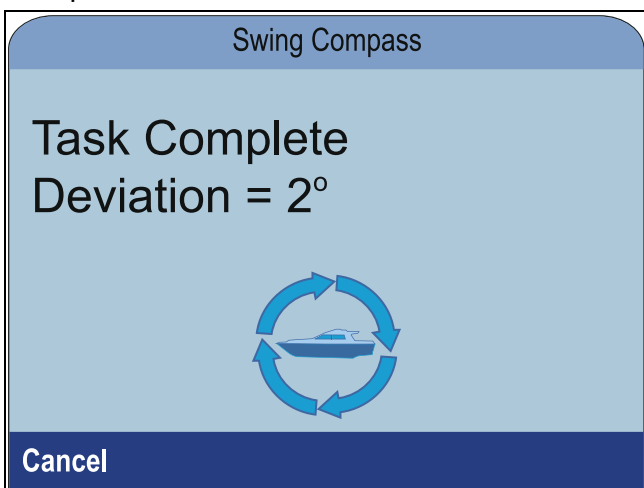

10. If the deviation is greater than 15 degrees you will need to relocate the Compass further away from

metal items or items that may cause interference, then repeat the calibration process. If you still find a deviation of more than 15 degrees, contact your Raymarine dealer for advice. If the deviation is within acceptable limits, press **Cancel**.

Setting the Compass Offset

You can manually apply an offset to the Compass heading by following the steps below.

To apply an offset you require a source of heading such as the ship's compass.

From the transducers found page:

1. Ensure that the Rudder is centred
2. Select **iTC-5**.
A list of available transducer data is displayed.
3. Select **Compass**.
4. Select **Compass Offset**.
5. Steer your vessel on a steady course.
6. Use the **Up** and **Down** buttons to adjust the Compass Offset until the displayed heading matches the heading of the ship's compass.
7. Select **Save**.



Chapter 8: Favorite Pages

Chapter contents

- [8.1 Favorite pages on page 52](#)
- [8.2 Customizing pages on page 52](#)



8.1 Favorite pages

The unit displays data on Favorite pages. The Favorite pages displayed are dependent on the Boat Type selected during the Startup Wizard.

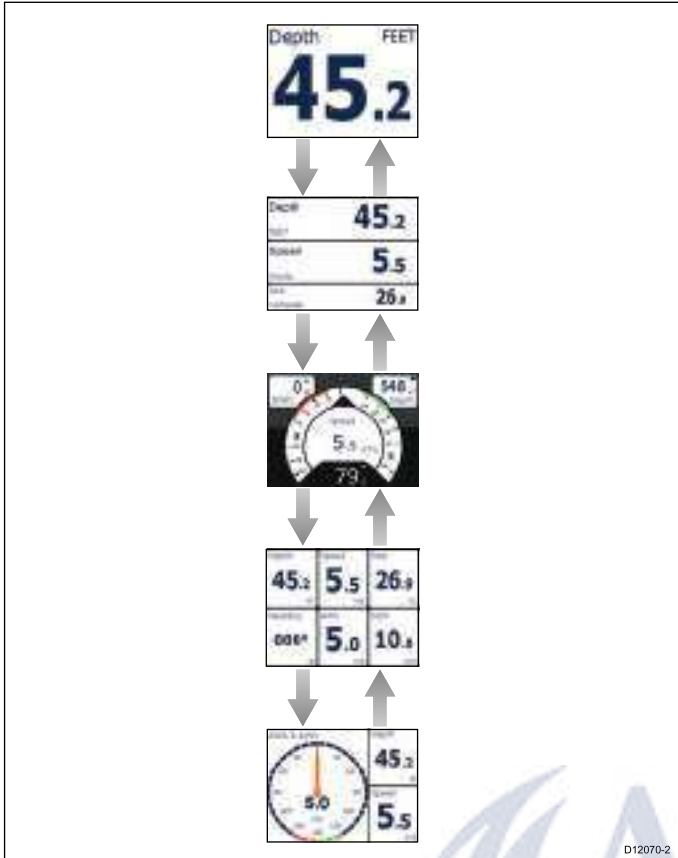

Selecting pages

1. Use the **Up** and **Down** buttons to cycle through the available pages.

Alternatively you can use the Rollover feature: (**Menu > Favorite Pages > Rollover**) to automatically cycle through the available pages.

8.2 Customizing pages

Favorite pages can be customized from the **Favorites page** menu. You can:

- Edit an existing page.
- Add new pages.
- Delete pages.
- Change page order.
- Set pages to Rollover

Editing an existing page

The layout and data displayed on each page can be changed.

With the page that you want to edit displayed onscreen:

1. Select **Menu**.
2. Select **Quick Options**.
3. Select **Edit Page**.
4. Select the page that you want to edit.

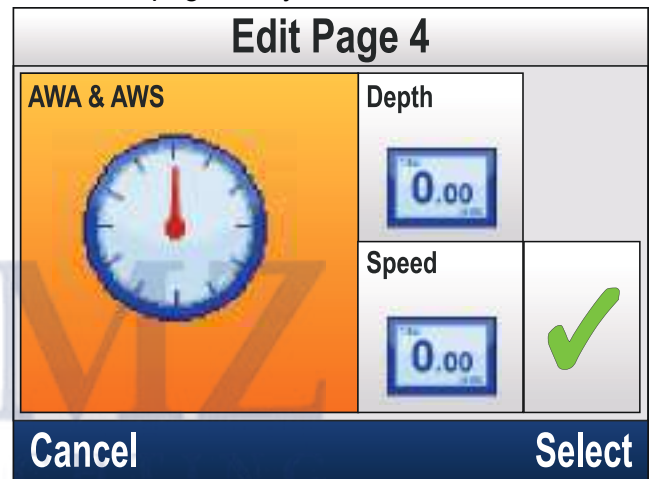

5. Use the **Up** and **Down** buttons to highlight the cell that you want to change.
6. Press the **Menu** button to choose a new data item.
7. Select a data item category.
8. Select the data item/layout from the category list.
If a data item cannot be displayed in the selected cell it will be grayed out.
9. Follow steps 5 to 8 for the remaining cells that you want to change.
10. When finished highlight the onscreen tick and select **Save**.

The **Edit page** menu is also available from the **Favorite Pages** menu: (**Menu > Favorite Pages > Edit Page**).

Adding a page

You can add new custom Favorite pages.

The maximum number of Favorite pages is 10.

From the Main menu:

1. Select **Favorite Pages**.
2. Select **New Page** from the menu.

If you already have 10 Favorite pages, you cannot add another page without first deleting one of the existing pages. Otherwise you will be taken to a page layout option screen.

3. Select the required layout.
4. Select a cell.
5. Browse the Data Categories list and select the Data item that you want to display in the selected cell.
6. Complete steps 2 and 3 for all remaining cells.
7. When finished highlight the onscreen tick and select **Save**.

The new page is added to the bottom of the current set of Favorite pages.

Deleting a page

To delete a page follow the steps below.

The minimum number of Favorite pages is one.

From the Favorite Pages menu: (**Menu > Favorite Pages**).

1. Select **Delete Page**.
If you have two or more pages you will be able to delete a page.
2. Select a the page that you want to delete.
3. Select **Yes**.

The page is now deleted.

Changing the page order

From the Favorite Pages menu: (**Menu > Favorite Pages**).

1. Select **Page order**.
2. Select the page you wish to move.
Page numbers are shown momentarily when you manually cycle through Favorite pages.
3. Use the **Up** and **Down** buttons to select the new location for the page.
4. Select **Save**.

Setting page Rollover

Using the Rollover feature enables the Favorite pages to cycle automatically.

From the **Favorite Pages** menu:

1. select **Rollover**.
2. Select a Time interval, or .
The Time intervals available are: 2 Secs, 5 Secs, and 10 Secs.
3. Select **Off** to switch Rollover off.

Resetting accumulative data

Minimum, Average, Maximum and distance data accumulates over time and can be reset.

The data item you want to reset must be displayed onscreen either as part of a Favorite page or as a Data (Quick view) page.

1. Press the **Menu** button.
2. Select **Quick Options**.
3. Select the relevant Reset options.



Chapter 9: Data (Quick View)

Chapter contents

- [9.1 Data items on page 56](#)
- [9.2 Viewing Data \(Quick View\) on page 58](#)
- [9.3 Adding a Quick View as a Favorite page on page 59](#)



9.1 Data items

The table below shows a list of possible data items available to display on **Favorite Pages** and using the **Data (Quick View)** menu.

Note: The data described in the table below is dependent on the devices that are connected to your system.

Data Category	Favorite Page (Data Items)	Quick View (Data Items)
AIS	<ul style="list-style-type: none"> • AIS 	<ul style="list-style-type: none"> • AIS
Battery ⁽¹⁾	<ul style="list-style-type: none"> • Battery Current • Battery Temperature • Battery Volts 	<ul style="list-style-type: none"> • Battery Current • Battery Temperature • Battery Volts
Boat	<ul style="list-style-type: none"> • Rate of Turn • Tilt • Trim Tabs • Gray Water Tank • Black Water Tank • Fresh Water Tank 	<ul style="list-style-type: none"> • Rate of Turn • Tilt
Depth	<ul style="list-style-type: none"> • Depth • Max Depth • Min Depth • Depth History 	<ul style="list-style-type: none"> • Depth • Depth History • Max Depth • Min Depth
Distance	<ul style="list-style-type: none"> • Log • Trip 	<ul style="list-style-type: none"> • Log • Trip
Engine ⁽¹⁾	<ul style="list-style-type: none"> • Engine Hours • Trim Position • RPM • Oil Pressure • Oil Temperature • Coolant Pressure • Coolant Temperature • Boost Pressure • Load • Alternator Potential • Transmission Oil Pressure • Transmission Oil Temperature • Transmission • 2 Engine Overview 	<ul style="list-style-type: none"> • Boost Pressure • Coolant Pressure • Coolant Temperature • Engine Hours • RPM • Oil Pressure • Oil Temperature • Trim Position • Load • Alternator Potential • Transmission Oil Pressure • Transmission Oil Temperature • Transmission • 2 Engine Overview

Data Category	Favorite Page (Data Items)	Quick View (Data Items)
	<ul style="list-style-type: none"> • 1 Engine Overview 	<ul style="list-style-type: none"> • 1 Engine Overview
Environment	<ul style="list-style-type: none"> • Sea Temperature • Max Sea Temperature • Min Sea Temperature • Sea Temperature History • Barometric Pressure • Barometric Pressure History • Air Temperature • Max Air Temperature • Min Air Temperature • Air Temperature History • Sunset / Sunrise • Set • Drift • Wind Chill Apparent • Wind Chill True • Dew Point • Humidity 	<ul style="list-style-type: none"> • Air Temperature • Air Temperature History • Barometric Pressure • Barometric Pressure History • Dew Point • Drift • Drift History • Humidity • Min Air Temperature • Max Air Temperature • Sea Temperature • Min Sea Temperature • Max Sea Temperature • Sea Temperature History • Set • Set History • Set & Drift Pair • Sunset / Sunrise • Wind Chill Apparent • Wind Chill True
Fuel ⁽¹⁾ Fuel management is dependent on engine data that is available on SeaTalk^{ng} ®.	<ul style="list-style-type: none"> • Distance To Empty • Fuel Flow Rate • Fuel Flow Rate Total • Fuel Flow – Average • Fuel Economy • Total Fuel • Est. Fuel Remaining • Fuel Level • Fuel Pressure 	<ul style="list-style-type: none"> • Distance To Empty • Fuel Flow Rate • Fuel Flow Rate Total • Fuel Economy • Fuel Flow – Average • Fuel Level • Total Fuel • Est. Fuel Remaining • Fuel Pressure

Data Category	Favorite Page (Data Items)	Quick View (Data Items)	Data Category	Favorite Page (Data Items)	Quick View (Data Items)
GPS	<ul style="list-style-type: none"> • SOG • SOG History • Max. SOG • Avg. SOG • COG • COG History • COG and SOG • Latitude • LAT & LON • Longitude • SATS • HDOP • SATS + HDOP 	<ul style="list-style-type: none"> • COG • COG History • COG and SOG • HDOP • Latitude • LAT & LON • Longitude • SATS • SATS + HDOP • SOG • SOG History • Max. SOG • Avg. SOG 	Navigation	<ul style="list-style-type: none"> • Active Waypoint Name • Waypoint ID • Course Made Good • CMG & DMG • CMG & VMG • Distance Made Good • BTW • BTW & DTW • DTW • XTE • ETA • TTG • Course to Steer • CTS & XTE • Rolling Road • Turn • Turn & DTW 	<ul style="list-style-type: none"> • Active Waypoint Name • Waypoint ID • Course Made Good • CMG History • BTW • DTW • BTW & DTW • Distance Made Good • CMG & DMG • CMG & VMG • Course to Steer • CTS & XTE • ETA • TTG • XTE • XTE History • Rolling Road • Turn • Turn & DTW
Heading	<ul style="list-style-type: none"> • Heading • Heading & speed • Heading History • Locked Heading • Error & Locked Heading • Tack Heading • Heading (Multi-gauge) 	<ul style="list-style-type: none"> • Heading • Heading & speed • Heading History • Locked Heading • Error & Locked Heading • Tack Heading • Heading (Multi-gauge) 	Pilot	<ul style="list-style-type: none"> • Pilot Heading • Pilot Heading & Speed Pair • Pilot Status • Rudder Angle 	<ul style="list-style-type: none"> • Pilot Heading • Pilot Heading & Speed Pair • Pilot Status • Rudder Angle
			Speed	<ul style="list-style-type: none"> • Speed • Trolling Speed • Max Speed • Average Speed • VMG Windward • VMG WPT • Boat Speed & SOG • Speed History 	<ul style="list-style-type: none"> • Average Speed • Boat Speed & SOG • Max Speed • Speed • Speed History • Trolling Speed • VMG Windward • VMG Windward History • VMG WPT • VMG WPT History

Data Category	Favorite Page (Data Items)	Quick View (Data Items)
Time	<ul style="list-style-type: none"> • Local Time • Time & Date • Clock • Race Timer 	<ul style="list-style-type: none"> • Clock • Local Time • Time & Date • Race Timer
Wind	<ul style="list-style-type: none"> • AWS • AWS History • AWS Min • AWS Max • AWA • AWA & AWS • AWA (CH) & AWS • AWA & VMG • AWA History • AWA Min • AWA Max • TWS • TWS History • TWS Min • TWS Max • TWA • TWA & TWS • TWA (CH) & TWS • TWA & VMG • TWA History • TWA Min • TWA Max • GWD • GWD & Beaufort • GWD History • Cardinal • Beaufort • TWD • TWD History 	<ul style="list-style-type: none"> • AWA • AWA History • AWA & AWS • AWA (CH) & AWS • AWA & VMG • AWA Max • AWA Min • AWS • AWS History • AWS Max • AWS Min • Beaufort • Cardinal • GWD • GWD History • GWD & Beaufort • TWD • TWD History • TWA • TWA History • TWA & TWS • TWA (CH) & TWS • TWA & VMG • TWA Max • TWA Min • TWS • TWS History • TWS Max • TWS Min

9.2 Viewing Data (Quick View)

You can use the **Data (Quick View)** menu to view data that may not be available on the current Favorite Pages.

1. Select **Data (Quick View)** from the main menu.
2. Select a Data Category.
3. Select the Data item and your preferred graphic type, if available.

The data will be displayed full screen.

Note: (1) There may be more than one device configured, Data items will be available for each configured device.

9.3 Adding a Quick View as a Favorite page

The Quick View data pages can be added as a Favorite page.

From the **Data (Quick View)** menu:

1. Select the Data item so that it is displayed onscreen.
2. Press the **Menu** button.
3. Select **Quick Options**.
4. Select **Add to Favorites**.





Chapter 10: AIS

Chapter contents

- [10.1 AIS Overview on page 62](#)
- [10.2 AIS target symbols on page 63](#)
- [10.3 Setting AIS Range on page 64](#)
- [10.4 Viewing AIS target information on page 64](#)
- [10.5 Enabling and disabling AIS Silent mode on page 65](#)



10.1 AIS Overview

When an AIS receiver/transceiver is connected to your system, the AIS feature enables you to receive information broadcast by other AIS equipped vessels, and to view these vessels as targets relative to your boat. The AIS feature on the unit is standalone, settings and alarms cannot be shared with other AIS enabled products on your system.

How AIS Works

AIS uses digital radio signals to broadcast 'real-time' information between vessels and shore-based stations via dedicated VHF radio frequencies. This information is used to identify and track vessels in the surrounding area and to provide fast, automatic and accurate collision avoidance data.

Note: It is not mandatory for vessels to be fitted with operational AIS equipment. Therefore, you should not assume that ALL vessels in your area are displayed.

With an optional AIS unit connected to your system you can:

- Display targets for any other AIS-equipped vessels.
- Display voyage information being broadcast by these targets, such as their position, course, speed and rate-of-turn.
- Display basic or detailed information for each target vessel, including safety-critical target data.
- Set up a safe zone around your vessel.
- View AIS alarm and safety-related messages.

AIS information is displayed on the screen as shown below:

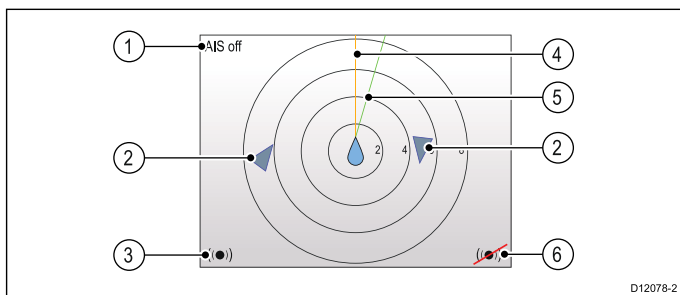

Item	Description
1	AIS text See AIS messages in table below
2	AIS target
3	Dangerous targets alarm on
4	Heading line
5	COG line
6	Dangerous targets alarm off

Note: Where unstable or no heading or COG data is available AIS targets and your vessel icon will not be displayed.









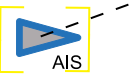

AIS Messages





AIS Messages	Description
AIS off	AIS Unit off
(none)	AIS is on and transmitting
Alarm on icon	AIS on, transmitting, alarm is active.
Silent	AIS on & user is silent to other vessels.
Alarm on	AIS on, user is silent to other vessels & alarm is active.
Alarm off icon	AIS on & Alarm off
Data lost	AIS on & data lost.
No fix	AIS on & lost GPS fix.
Insufficient COG/Hdg data	No stable COG or heading data

AIS-equipped vessels in the surrounding area are displayed on the page as targets. A maximum of 25 targets can be displayed, where more than 25 targets are in range **Max targets** is displayed onscreen.

10.2 AIS target symbols

Your display shows a range of symbols to represent the different types of AIS target.

Target type	Description	Symbol
Transmitting target	Target not activated, dangerous or lost. Target is moving or at anchor.	
Selected target	Target selected with cursor. Can view detailed data.	
Dangerous target	Targets within specified distance (CPA) or time (TCPA). Dangerous target alarm sounds if enabled. Target red and flashes.	
Uncertain target	Calculated CPA / TCPA value uncertain.	
Lost target	When signal of dangerous target not received for 20 seconds. Target in latest predicted position. Alarms sounds if enabled. Target with red cross and flashes.	
Aid To Navigation (AToN) target (Real)	AToN target is ON position.	
Aid To Navigation (AToN) target (Real)	AToN target is OFF position. Target red.	
Aid To Navigation (AToN) target (Real)	AToN target is OFF position & dangerous. Target black and flashes.	
Aid To Navigation (AToN) target (Real)	AToN target is OFF position & lost. Target black with red cross and flashes.	
Aid To Navigation (AToN) target (Virtual)	AToN target is ON position.	
Aid To Navigation (AToN) target (Virtual)	AToN target is OFF position. Target red.	
Aid To Navigation (AToN) target (Virtual)	AToN target is OFF position & dangerous. Target black and flashes.	

Target type	Description	Symbol
Aid To Navigation (AToN) target (Virtual)	AToN target is OFF position & lost. Target black with red cross and flashes.	
Land base station target	Land base station target is ONLINE.	
Yacht	Target vessel type is a yacht.	
Commercial Vessel	Target vessel type is a commercial vessel.	
High speed vessel	Target vessel type is a high speed vessel.	

10.3 Setting AIS Range

The distance displayed on the AIS page can be adjusted.

With the AIS page displayed:

1. Press the **Menu** button.
2. Select **Quick options** .
3. Select **AIS Range**.
4. Select the Range you want to display.

10.4 Viewing AIS target information

You can view information about AIS targets.

With the AIS page displayed:

1. Press the **Menu** button.
2. Select **Quick Options**.
3. Select **View AIS targets**.
4. Use the **Up** and **Down** buttons to select an AIS target.
The Name of the vessel will be displayed in the page header.
5. Select **Info** to view detailed target information.
The information displayed is dependent on the type of target selected.
 - Vessel name
 - MMSI number
 - Vessel type
 - Call sign
 - SOG
6. Use the **Up** and **Down** buttons to scroll through the data.
7. To return to the AIS page, select **Back** .



10.5 Enabling and disabling AIS Silent mode

AIS silent mode enables you to disable the transmitting functions of your AIS equipment. This is useful when you do not want to transmit your vessel's AIS data to other AIS receivers, but still wish to receive data from other vessels.

Note: Not all AIS equipment supports silent mode. For more information, refer to the documentation that accompanied your AIS unit.

From the AIS page:

1. Press the **Menu** button.
2. Select **Quick options**.
3. Select **AIS Silent mode**.
4. Select **Silent** to stop your AIS position and details being transmitted, or
5. Select **Transmit** to allow your AIS position and details to be received by other AIS equipped vessels.





Chapter 11: Race timer settings

Chapter contents

- [11.1 Setting the Race Timer on page 68](#)
- [11.2 Using the Race Timer on page 68](#)



11.1 Setting the Race Timer

The Race Timer is used to show the time elapsed since the start of a race. The Race Timer has 3 countdown timers. When a timer count down is complete (reaches zero) then the Race Timer will start to count up.

If the Race Timer has not been added as a Favorite Page then it can be accessed from the **Data (Quick View)** menu: **Menu > Data (Quick View) > Time > Race Timer**.

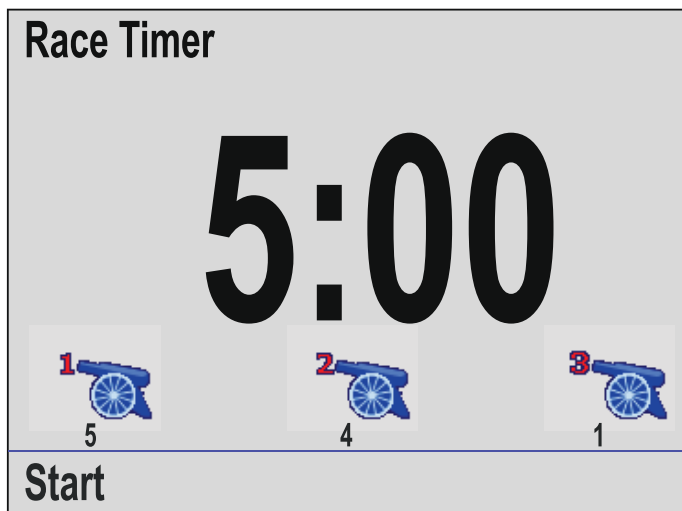

With the Race Timer page displayed:

1. Press the **Menu** button.
2. Select **Quick Options**.
3. Select **Adjust start timers**.
4. Select a start timer
5. Use the **Up** and **Down** buttons to adjust the timer to the required value.
6. Select **Save**.
7. Complete steps 4 to 6 for each start timer you want to adjust.

11.2 Using the Race Timer

With the Race Timer page displayed:

1. Select **Start**.
The first start timer will begin to count down, audible beeps are sounded as follows:
 - Double beep every minute.
 - Beep Three times at the start of the last 30 seconds.
 - Beep every second for the last 10 seconds.
 - Beep for two seconds when the timer reaches zero
2. You can select **Skip** to skip to the next start timer.
With the third start timer counting down you can select **Count up** to start the timer counting up from zero.
3. You can stop the start timer count down by selecting **Stop** from the **Quick Options** menu.
4. When stopped, you can resume the count down by selecting **Resume**.
5. The Race Timer page can be reset by selecting **Reset Timer** from the **Quick Options** menu.

Note: You can view other Favorite pages and menus whilst the Race Timer is running.



Chapter 12: Instrument alarms

Chapter contents

- [12.1 Alarms on page 70](#)



12.1 Alarms

Alarms are used to alert you to a situation or hazard requiring your attention.

Some examples of alarms are:

- Anchor alarm — Used when anchored, this alerts you to a change in depth which could mean that the chain length requires adjusting.
- Depth and speed alarms — These alarms alert you when your depth or speed moves outside of specified limits, for example a minimum depth.
- MOB (Man Overboard) alarm — Received from an MOB system.

When an alarm occurs, a message is displayed and an audible alarm may sound.



You can either:

- Silence the alarm, or
- Silence the alarm and edit the alarm settings.

Note: With the exception of the Alarm clock, Speed and Sea temperature; SeaTalk systems will only be able to switch alarms on and off, SeaTalk^{ng} systems will also be able to adjust settings.

Man over Board (MoB) alarm

In the event of a MOB alarm, the instrument provides details to help find the MoB target.

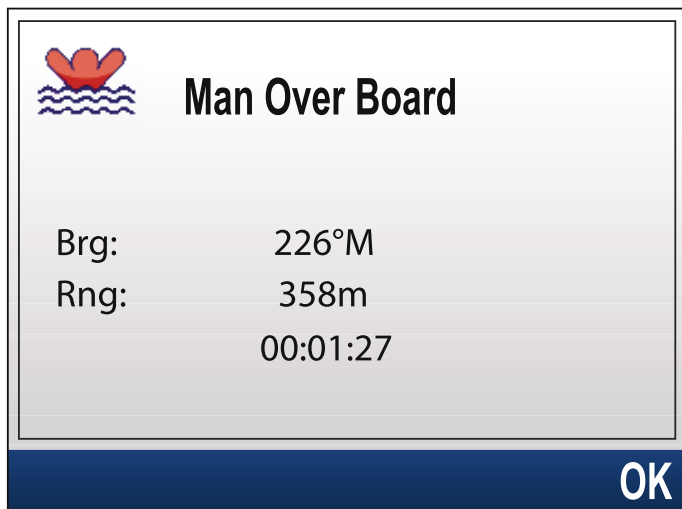

- Brg: Bearing to MoB waypoint.
- Rng: Range to MoB waypoint.
- Elapsed time since start of MoB alarm.

Bearing and Range require GPS data to be available on the network.

Alarm settings

Most alarms are generated locally using specified thresholds. They are also transmitted to the SeaTalk and SeaTalk^{ng} networks for display at other compatible devices.

Category	Alarm		Content
Depth	Shallow	Alarm	<ul style="list-style-type: none"> • On • Off (default)
		Adjust	<ul style="list-style-type: none"> • 0 — xxx FT • 5 ft (default)
Depth	Deep	Alarm	<ul style="list-style-type: none"> • On • Off (default)
		Adjust	<ul style="list-style-type: none"> • 0 — xxx FT • 100 ft (default)
Depth	Shallow Anchor	Alarm	<ul style="list-style-type: none"> • On • Off (default)
		Adjust	<ul style="list-style-type: none"> • 0 — xxx FT • 5 ft (default)
Depth	Deep Anchor	Alarm	<ul style="list-style-type: none"> • On • Off (default)
		Adjust	<ul style="list-style-type: none"> • 0 — xxx FT • 100 ft (default)
Speed	Boat Speed High	Alarm	<ul style="list-style-type: none"> • On • Off (default)
		Adjust	<ul style="list-style-type: none"> • 0 — 100 KTS • 30 kts (default)
Speed	Boat Speed Low	Alarm	<ul style="list-style-type: none"> • On • Off (default)
		Adjust	<ul style="list-style-type: none"> • 0 — 100 KTS • 5 kts (default)

Category	Alarm		Content
Temperature	Sea Temp. High	Alarm	<ul style="list-style-type: none"> On Off (default)
		Adjust	<ul style="list-style-type: none"> 0 — 50°C 10°C (default)
Temperature	Sea Temp. Low	Alarm	<ul style="list-style-type: none"> On Off (default)
		Adjust	<ul style="list-style-type: none"> 0 — 50°C 1°C (default)
Wind	AWS High Apparent Wind Speed high	Alarm	<ul style="list-style-type: none"> On Off (default)
		Adjust	<ul style="list-style-type: none"> 0 — 200 KTS 25 kts (default)
Wind	AWS Low Apparent Wind Speed low	Alarm	<ul style="list-style-type: none"> On Off (default)
		Adjust	<ul style="list-style-type: none"> 0 — 200 KTS 10 kts (default)
Wind	AWA High Apparent Wind Angle high	Alarm	<ul style="list-style-type: none"> On Off (default)
		Adjust	<ul style="list-style-type: none"> 0 — 180° 25° (default)
Wind	AWA Low Apparent Wind Angle low	Alarm	<ul style="list-style-type: none"> On Off (default)
		Adjust	<ul style="list-style-type: none"> 0 — 180° 10° (default)
Wind	TWS High True Wind Speed high	Alarm	<ul style="list-style-type: none"> On Off (default)
		Adjust	<ul style="list-style-type: none"> 0 — 200 KTS 10 kts (default)

Category	Alarm		Content
Wind	TWS Low True Wind Speed low	Alarm	<ul style="list-style-type: none"> On Off (default)
		Adjust	<ul style="list-style-type: none"> 0 — 200 KTS 10 kts (default)
Wind	TWA High True Wind Angle high	Alarm	<ul style="list-style-type: none"> On Off (default)
		Adjust	<ul style="list-style-type: none"> 0 — 180° 25° (default)
Wind	TWA Low True Wind Angle low	Alarm	<ul style="list-style-type: none"> On Off (default)
		Adjust	<ul style="list-style-type: none"> 0 — 180° 10° (default)
Other	Alarm Clock	Alarm	<ul style="list-style-type: none"> On Off (default)
		Time	<ul style="list-style-type: none"> 12:00 am — 12:00 pm 00:00 – 23:59 24 hr
		Format	<ul style="list-style-type: none"> 24 hour am / pm
Other	Off Course	Alarm	<ul style="list-style-type: none"> On Off (default)
		Adjust	<ul style="list-style-type: none"> 0 — 180° 5° (default)
Other	MOB Man Overboard	Alarm	<ul style="list-style-type: none"> On (default) Off
Other	Battery Low	Alarm	<ul style="list-style-type: none"> On Off (default)
		Adjust	<ul style="list-style-type: none"> 6 – 60 V 10 V (default)

Category	Alarm		Content
Other	AIS Alarm	Safety messages	<ul style="list-style-type: none"> • On • Off (default)
		Dangerous target	<ul style="list-style-type: none"> • On • Off (default)
		Safe zone	<ul style="list-style-type: none"> • (0.1 , 0.2, 0.5, 1.0, 2.0) nm • (0.1 , 0.2, 0.5, 1.0, 2.0) sm • (0.2, 0.5, 1.0, 2.0, 5.0) km
		Time to safe zone	<ul style="list-style-type: none"> • 3 min • 6 min • 12 min • 24 min



Chapter 13: Setup menu

Chapter contents

- [13.1 Setup menu on page 74](#)



13.1 Setup menu

The Set-up menu provides settings to configure the unit.

Menu item	Description	Options
Transducer Set-up	Set up and calibrate transducers as detailed in Transducer calibration section above.	List of connected, compatible transducers.
User Preferences	Configure User Preferences.	<ul style="list-style-type: none"> • Time & Date • Units • Language • Boat Type • Boat Details • Variation • Key Beep
System set up	Configure network groups and data sources.	<ul style="list-style-type: none"> • Network group • Brightness/Color Group • Data Sources • About System Set Up
Simulator	<p>Enables and disables simulator mode. The simulator produces simulated data to enable you to practice operating the unit.</p> <div style="border: 1px solid black; padding: 5px; margin-top: 10px;"> <p>Note: The Simulator will not product simulated data if other product are present on the SeaTalk^{ng}® network.</p> </div>	<ul style="list-style-type: none"> • On • Off
Factory reset	Delete user settings and Restore unit to factory default settings.	<ul style="list-style-type: none"> • Yes • No
Diagnostics	Information About the unit, device connected to the network and a diagnostics Self Test.	<ul style="list-style-type: none"> • About display • About system • Self Test

Transducer setup menu

The **Transducer Set-up** menu enables calibration of connected transducers.

Menu item	Description	Options
iTC-5	Enables setup and calibration of transducers connected using an iTC-5.	<ul style="list-style-type: none"> • Depth • Speed • Wind • Rudder reference • Compass
Depth	Enables setup and calibration of depth transducers and provides the following options: <ul style="list-style-type: none"> • Details • Depth offset 	<p>Details displays can supply information about the installed transducer or interface such as Serial No. and Software version etc.</p> <p>Depth offset allows you to set the offset distance so that the displayed depth reading represents the depth to the sea bed from either the keel or the waterline.</p> <ul style="list-style-type: none"> • Depth from: <ul style="list-style-type: none"> – Keel – Transducer – Water line • Offset: <ul style="list-style-type: none"> – 0 to 99 ft, m • About depth offset
Speed	Enables setup and calibration of speed transducers and provides the following options: <ul style="list-style-type: none"> • Details • Speed calibration speed should be calibrated at each of the speed points shown under speed calibration. • Calibrate water temperature 	<p>Details displays can supply information about the installed transducer or interface such as Serial No. and Software version etc.</p> <p>Speed calibration:</p> <ul style="list-style-type: none"> • speed settings are determined by the calibration points stored either in the transducer or the interface unit. <p>Calibrate water temperature:</p> <ul style="list-style-type: none"> • xxx °C or °F
Wind	Enables setup and calibration of wind transducers and provides the following options: <ul style="list-style-type: none"> • Wind detail • Calibrate vane • App wind speed calibration 	<p>Details displays information about the installed transducer, Serial No. and Software version etc.</p> <p>Calibrate vane- follow the on screen instructions to calibrate the wind vane.</p> <p>App wind speed:</p> <ul style="list-style-type: none"> • xx kts
DST800	Enables setup and calibration of DST (Depth, Speed, and Temperature) smart transducers and provides the following options: <ul style="list-style-type: none"> • DST800 details • Depth offset • Speed calibration • Temperature offset 	<p>DST800 details displays information about the installed transducer, Serial No. and Software version etc.</p> <p>Depth offset allows you to set the offset distance so that the displayed depth reading represents the depth to the sea bed from either the keel or the waterline.</p> <ul style="list-style-type: none"> • Depth from: <ul style="list-style-type: none"> – Water line – Keel – Transducer • Offset: <ul style="list-style-type: none"> – 0 to 99 ft • About depth offset

Menu item	Description	Options
		<p>Speed calibration:</p> <ul style="list-style-type: none"> • Add — adds a new speed setting using current SOG reading. • Edit — edits a speed setting in 0.1 kt increments. • Delete — deletes the selected speed setting. • Reset — resets speed calibration to default settings. <p>Temperature offset:</p> <ul style="list-style-type: none"> • xxx °C or °F
<p>DT800</p>	<p>Enables setup and calibration of DT (Depth, and Temperature) smart transducers and provides the following options:</p> <ul style="list-style-type: none"> • DT800 details • Depth offset • Temperature offset 	<p>DT800 details displays information about the installed transducer, Serial No. and Software version etc.</p> <p>Depth offset allows you to set the offset distance so that the displayed depth reading represents the depth to the sea bed from either the keel or the waterline.</p> <ul style="list-style-type: none"> • Depth from: <ul style="list-style-type: none"> – Water line – Keel – Transducer • Offset: <ul style="list-style-type: none"> – 0 to 99 ft, m • About depth offset <p>Temperature offset:</p> <ul style="list-style-type: none"> • xxx °C or °F

User Preferences menu

The **User Preferences** menu enables you to customize the unit settings.

Menu item	Description	Options
Time & Date	These options enable you to customize the date and time format to your requirements. You can also specify a local time offset from Universal Time Constant (UTC), to compensate for any time zone difference.	Date format: <ul style="list-style-type: none"> • mm/dd/yy • dd/mm/yy Time format: <ul style="list-style-type: none"> • 12hr • 24hr Time offset: <ul style="list-style-type: none"> • -13 to +13 hours
Units	Enables you to specify the units used for the following key measurements: <ul style="list-style-type: none"> • Speed • Distance • Depth • Wind speed • Temperature • Flow rate • Heading • Pressure • Volume • Barometric 	Speed: <ul style="list-style-type: none"> • kts — knots. • mph — miles per hour. • km/h — Kilometers per hour. Distance: <ul style="list-style-type: none"> • nm — Nautical miles. • sm — Statute miles. • km — Kilometers. Depth: <ul style="list-style-type: none"> • ft — Feet • m — Metres • fa — Fathoms Wind speed: <ul style="list-style-type: none"> • kts — knots. • m/s — metres per second. Temperature: <ul style="list-style-type: none"> • °C — degrees centigrade. • °F — degrees fahrenheit. Flow Rate <ul style="list-style-type: none"> • UK Gal/H — UK gallons per hour. • US Gal/H — US gallons per hour. • LPH — Liters per hour. Heading: <ul style="list-style-type: none"> • Mag — magnetic. • True Pressure <ul style="list-style-type: none"> • PSI — pounds per square inch. • Bar — bar. • kPa — Kilo pascals. Volume: <ul style="list-style-type: none"> • UK Gallons • US Gallons • ltr — liter.

Menu item	Description	Options
Language	Determines the language that will be used for all on-screen text, labels, menus and options.	<ul style="list-style-type: none"> • English (UK) • English (US) • Chinese • Croatian • Danish • Dutch • Finnish • French • German • Greek • Italian • Japanese • Korean • Norwegian • Polish • Portuguese (Brazilian) • Russian • Spanish • Swedish • Turkish
Boat Type	Determines the default setup of the unit and favorite pages	<ul style="list-style-type: none"> • Race Sail • Sail Cruiser • Catamaran • Workboat • RIB • Outboard Speedboat • Inboard Speedboat • Power Cruiser 1 (<12kts) • Power Cruiser 2 (<30kts) • Power Cruiser 3 (>30kts) • Sport Fishing • Pro Fishing
Boat Details	Enable you to specify the following: <ul style="list-style-type: none"> • Number of engines • Number of batteries • Number of fuel tanks • Max RPM range • RPM Red Zone 	Number of engines: <ul style="list-style-type: none"> • 1 — 5 Number of batteries <ul style="list-style-type: none"> • 1 — 5 Number of fuel tanks <ul style="list-style-type: none"> • 1 — 5 Max RPM range <ul style="list-style-type: none"> • Auto (default) • 3000 rpm • 4000 rpm • 5000 rpm

Menu item	Description	Options
		<ul style="list-style-type: none"> • 6000 rpm • 7000 rpm • 8000 rpm • 9000 rpm • 10000 rpm <p>RPM Red Zone</p> <ul style="list-style-type: none"> • Auto (default) • Custom value
Variation	<p>Enables you to turn on and off magnetic variation, specify slave source or adjust manually.</p> <ul style="list-style-type: none"> • Variation mode • Variation range 	<p>Variation mode:</p> <ul style="list-style-type: none"> • On • Off (default) • Slave <p>Variation range:</p> <ul style="list-style-type: none"> • -30° — +30°
Key Beep	<p>Enable and disable the audible beep when pressing buttons.</p>	<ul style="list-style-type: none"> • On (default) • Off



System set-up menu

The **System set-up** menu enables users to customize the following user settings:

Menu item	Description	Options
Network group	Allows adding multiple units together in a group so that when the color scheme or brightness is changed on one unit the changes are applied to all units in the group.	Predefined groups <ul style="list-style-type: none"> • None • Helm 1 • Helm 2 • Cockpit • Flybridge • Mast Undefined <ul style="list-style-type: none"> • Group-1 — Group-5
Brightness / color group	Enables synchronization of the displays brightness and color to be the same as the other units in the same group.	Sync brightness / color <ul style="list-style-type: none"> • This display • This group
Data sources	Allows you to view and select preferred data sources. <ul style="list-style-type: none"> • Select data source • Data source found • Data source details 	Select data source <ul style="list-style-type: none"> • GPS position • GPS Datum • Time & Date • Heading • Depth • Speed • Wind Data source found <ul style="list-style-type: none"> • model name — serial number Port ID Data source details <ul style="list-style-type: none"> • Device name • Serial No. • Port ID • Status or No data
About system set-up	Provides information about the System set-up menu.	

Diagnostics menu

You can access diagnostics details from the **Diagnostics** menu: (**Menu > Set-up > Diagnostics**).

Menu item	Description	Options
About display	Allows you to view information about the display you are using:	<ul style="list-style-type: none"> • Software version • Hardware version • Bootloader version • Temperature • Volts • Max. volts • Current • Max. current • Run time • Deviation (If available)
About Pilot	Allows you to view information about the autopilot you are using: <div style="border: 1px solid black; padding: 5px; margin-top: 10px;"> <p>Note: The About Pilot menu is only available on Pilot controllers.</p> </div>	<ul style="list-style-type: none"> • NMEA Code • Product ID • Serial number • Description • Software version • PCB Number • CAN Volts • Unit Volts • Operating hours • Deviation
About system	Allows you to search the SeaTalk^{ng} network and display information about the products found.	<ul style="list-style-type: none"> • Model number • Serial number • Software version • Hardware version • Volts
Self test	The product has a built in self test which can help to diagnose faults. Self-Test include: <ul style="list-style-type: none"> • Memory test • Button test • Display test • Buzzer test • Illumination test 	N/A



Chapter 14: Maintenance

Chapter contents

- 14.1 Service and maintenance on page 84
- 14.2 Routine equipment checks on page 84
- 14.3 Product cleaning on page 85
- 14.4 Cleaning the display case on page 85
- 14.5 Cleaning the display screen on page 86
- 14.6 Cleaning the sun cover on page 86



14.1 Service and maintenance

This product contains no user serviceable components. Please refer all maintenance and repair to authorized Raymarine dealers. Unauthorized repair may affect your warranty.

14.2 Routine equipment checks

Raymarine strongly recommends that you complete a number of routine checks to ensure the correct and reliable operation of your equipment.

Complete the following checks on a regular basis:

- Examine all cables for signs of damage or wear and tear.
- Check that all cables are securely connected.



14.3 Product cleaning

Best cleaning practices.

When cleaning products:

- If your product includes a display screen, do NOT wipe the screen with a dry cloth, as this could scratch the screen coating.
- Do NOT use abrasive, or acid or ammonia based products.
- Do NOT use a jet wash.

14.4 Cleaning the display case

The display unit is a sealed unit and does not require regular cleaning. If it is necessary to clean the unit, follow this basic procedure:

1. Switch off the power to the display.
2. Wipe the display with a clean, soft cloth (a microfibre cloth is ideal).
3. If necessary, use a mild detergent to remove grease marks.

Note: Do NOT use solvents or detergents on the screen itself.

Note: In certain conditions, condensation may appear inside the display screen. This will not harm the unit, and can be cleared by powering on the display for a short time.



14.5 Cleaning the display screen

A coating is applied to the display screen. This makes it water repellent, and prevents glare. To avoid damaging this coating, follow this procedure:

1. Switch off the power to the display.
2. Rinse the screen with fresh water to remove all dirt particles and salt deposits.
3. Allow the screen to dry naturally.
4. If any smears remain, very gently wipe the screen with a clean microfibre cleaning cloth (available from an opticians).

Transducer care and cleaning

Growth can collect on the bottom of the transducer, this can reduce performance. To prevent the build-up of sea growth, coat the transducer with a thin layer of water-based antifouling paint, available from your local marine dealer. Reapply paint every 6 months or at the beginning of each boating season. Certain smart transducers have restrictions on where antifouling paint is applied. Please consult your dealer.

Note: Transducers with a temperature sensor may not work properly if painted.

Note: Never use ketone-based paint. Ketones can attack many plastics, possibly damaging the sensor.

Note: Never use spray paint on your transducer. Spraying incorporates tiny air bubbles, and a marine transducer cannot transmit properly through air.

Use a soft cloth and mild household detergent to clean the transducer. If the fouling is severe, remove the growth with a tough cleaning pad, such as a green Scotch Brite™ pad for example. Be careful to avoid scratching the face of the transducer.

Note: Harsh cleaning solvents such as acetone WILL damage the transducer.

14.6 Cleaning the sun cover

The supplied sun cover features an adhesive surface. In certain conditions unwanted contaminants may stick to this surface. To avoid damaging the monitor display, clean the sun cover regularly following this procedure:

1. Carefully remove the sun cover from the display.
2. Rinse the sun cover with fresh water to remove all dirt particles and salt deposits.
3. Allow the sun cover to dry naturally.

Chapter 15: System checks and troubleshooting

Chapter contents

- 15.1 Troubleshooting on page 88
- 15.2 Power up troubleshooting on page 89
- 15.3 System data troubleshooting on page 90
- 15.4 Miscellaneous troubleshooting on page 91
- 15.5 Performing a Factory Reset on page 92



15.1 Troubleshooting

The troubleshooting information provides possible causes and corrective action required for common problems associated with marine electronics installations.

All Raymarine products are, prior to packing and shipping, subjected to comprehensive test and quality assurance programs. However, if you experience problems with the operation of your product this section will help you to diagnose and correct problems in order to restore normal operation.

If after referring to this section you are still having problems with your unit, please contact Raymarine Technical Support for further advice.



15.2 Power up troubleshooting

Problems at power up and their possible causes and solutions are described here.

Product does not turn on or keeps turning off

Possible causes	Possible solutions
Blown fuse / tripped breaker	<ol style="list-style-type: none"> 1. Check condition of relevant fuses and breakers and connections, replace if necessary (Refer to the <i>Technical Specification</i> section of your product's installation instructions for fuse ratings.) 2. If fuse keeps blowing check for cable damage, broken connector pins or incorrect wiring.
Poor / damaged / insecure power supply cable / connections	<ol style="list-style-type: none"> 1. Check that the power cable connector is fully inserted into the unit and locked in position. 2. Check the power supply cable and connectors for signs of damage or corrosion, replace if necessary. 3. With the unit turned on, try flexing the power cable near to the display connector to see if this causes the unit to re-boot/loose power, replace if necessary. 4. Check the vessel's battery voltage, the condition of the battery terminals and power supply cables, ensuring connections are secure, clean and free from corrosion, replace if necessary. 5. With the product under load, using a multi-meter, check for high voltage drop across all connectors/fuses etc, replace if necessary.
Incorrect power connection	The power supply may be wired incorrectly, ensure the installation instructions have been followed.
Power source insufficient	With the product under load, using a multi-meter, check the power supply voltage as close to the unit as possible to establish actual voltage when the current is flowing. (Refer to the <i>Technical Specification</i> section of your product's installation instructions for power supply requirements.)

Product will not boot up (re-boot loop)

Possible causes	Possible solutions
Power supply and connection	See possible solutions from 'Products does not turn on or keeps turning off' above.
Software corruption	<ol style="list-style-type: none"> 1. In the unlikely event that the products software has become corrupted please try re-flashing the latest software from the Raymarine website. 2. On display products, as a last resort, you can try to perform a 'Power on Reset', however this will delete all settings/presets and user data (such as waypoints and tracks) and revert the unit back to factory defaults.

15.3 System data troubleshooting

Aspects of the installation can cause problems with the data shared between connected equipment. Such problems, their possible causes and solutions are described here.

Problem	Possible causes	Possible solutions
Instrument, engine or other system data is unavailable at all displays.	Data is not being received at the display.	Check the data bus (e.g. SeaTalk^{ng}) wiring and connections.
		Check the overall integrity of the data bus (e.g. SeaTalk^{ng}) wiring.
		If available refer to the reference guide for the data bus (e.g. SeaTalk^{ng} reference manual).
	Data source (e.g. instrument display or engine interface) is not operating.	Check the source of the missing data (e.g. instrument display or engine interface).
		Check the power to the SeaTalk bus.
		Refer to the manufacturer's handbook for the equipment in question.
Software mismatch between equipment may prevent communication.	Contact Raymarine technical support.	
Instrument or other system data is missing from some but not all displays.	Network problem.	Check that all required equipment is connected to the network.
		Check the status of the Raymarine network Switch.
		Check that SeaTalk^{hs} / RayNet cables are free from damage.
	Software mismatch between equipment may prevent communication.	Contact Raymarine technical support.
Position data is not displayed on VHF radio	VHF radio NMEA 0183 input not isolated / incorrect polarity	<ul style="list-style-type: none"> • Check that the radio has an Isolated NMEA 0183 input. • Check polarity of NMEA 0183 wires.

15.4 Miscellaneous troubleshooting

Miscellaneous problems and their possible causes and solutions are described here.

Problem	Possible causes	Possible solutions
Display behaves erratically: <ul style="list-style-type: none"> • Frequent unexpected resets. • System crashes or other erratic behavior. 	Intermittent problem with power to the display.	Check relevant fuses and breakers.
		Check that the power supply cable is sound and that all connections are tight and free from corrosion.
		Check that the power source is of the correct voltage and sufficient current.
	Software mismatch on system (upgrade required).	Go to www.raymarine.com and click on support for the latest software downloads.
	Corrupt data / other unknown issue.	Perform a factory reset. <div style="border: 1px solid black; padding: 5px; margin-top: 5px;"> <p>Important: This will result in the loss of any settings and data (such as waypoints) stored on the product. Save any important data to a memory card before resetting.</p> </div>



15.5 Performing a Factory Reset

To reset your unit to factory default settings follow the steps below.

Note: Performing a factory reset will erase all saved data and customized settings.

1. Press the **Menu** button.
2. Select **Set Up**.
3. Select **Factory Reset**.
4. Select **Yes**.

Your unit will now reset itself to factory default settings.



Chapter 16: Technical support

Chapter contents

- [16.1 Raymarine product support and servicing on page 94](#)
- [16.2 Viewing product information on page 95](#)



16.1 Raymarine product support and servicing

Raymarine provides a comprehensive product support service, as well as warranty, service, and repairs. You can access these services through the Raymarine website, telephone, and e-mail.

Product information

If you need to request service or support, please have the following information to hand:

- Product name.
- Product identity.
- Serial number.
- Software application version.
- System diagrams.

You can obtain this product information using the menus within your product.

Servicing and warranty

Raymarine offers dedicated service departments for warranty, service, and repairs.

Don't forget to visit the Raymarine website to register your product for extended warranty benefits: <http://www.raymarine.co.uk/display?id=788>.

Region	Tele- phone	E-mail
United Kingdom (UK), EMEA, and Asia Pacific	+44 (0)1329 246 932	emea.service@raymarine.com
United States (US)	+1 (603) 324 7900	rm-usrepair@flir.com

Web support

Please visit the "Support" area of the Raymarine website for:

- **Manuals and Documents** — <http://www.raymarine.com/manuals>
- **FAQ / Knowledgebase** — <http://www.raymarine.com/knowledgebase>
- **Technical support forum** — <http://forum.raymarine.com>
- **Software updates** — <http://www.raymarine.com/software>

Telephone and e-mail support

Region	Tele- phone	E-mail
United Kingdom (UK), EMEA, and Asia Pacific	+44 (0)1329 246 777	support.uk@raymarine.com
United States (US)	+1 (603) 324 7900 (Toll-free: +800 539 5539)	support@raymarine.com

Region	Tele- phone	E-mail
Australia and New Zealand	+61 2 8977 0300	aus.support@raymarine.com (Raymarine subsidiary)
France	+33 (0)1 46 49 72 30	support.fr@raymarine.com (Raymarine subsidiary)
Germany	+49 (0)40 237 808 0	support.de@raymarine.com (Raymarine subsidiary)
Italy	+39 02 9945 1001	support.it@raymarine.com (Raymarine subsidiary)
Spain	+34 96 2965 102	sat@azimut.es (Authorized Raymarine distributor)
Netherlands	+31 (0)26 3614 905	support.nl@raymarine.com (Raymarine subsidiary)
Sweden	+46 (0)317 633 670	support.se@raymarine.com (Raymarine subsidiary)
Finland	+358 (0)207 619 937	support.fi@raymarine.com (Raymarine subsidiary)
Norway	+47 692 64 600	support.no@raymarine.com (Raymarine subsidiary)
Denmark	+45 437 164 64	support.dk@raymarine.com (Raymarine subsidiary)
Russia	+7 495 788 0508	info@mikstmarine.ru (Authorized Raymarine distributor)

16.2 Viewing product information

1. Press the **Menu** button.
2. Select **Set-up**.
3. Select **Diagnostics**.
4. Select **About Display**.

A range of information is displayed, including the software version and Serial number.

5. Use the **Up** and **Down** buttons to cycle through the information.





Chapter 17: Technical specification

Chapter contents

- [17.1 Technical specification on page 98](#)



17.1 Technical specification

Nominal supply voltage	12 V dc
Operating voltage range	9 V dc to 16 V dc (protected up to 32 V dc)
Current	143 mA
Power consumption	1.7 W
LEN (Refer to the SeaTalk ^{ng} reference manual for further information.)	3
Operating Temperature Range	-20°C to 55°C (-4°F to 131°F)
Storage Temperature Range	-30°C to 70°C (-22°F to 158°F)
Relative Humidity	93% Max.
Water proofing	IPX6 and IPX7
Display screen	<ul style="list-style-type: none"> • 4.1" TFT LCD display • 16bit color (64k colors) • Resolution: 320(H) x 240(V) • Brightness: 1,200 cd/m2
Data connections	1 x SeaTalk^{ng} ® connector
Conformance	<ul style="list-style-type: none"> • NMEA 2000 certification pending • Europe 2004/108/EC • Australia and New Zealand C-Tick, compliance level 2

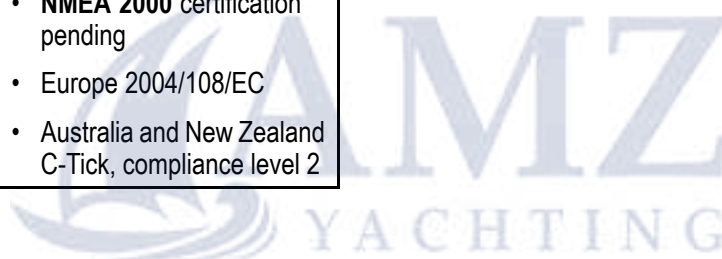

Chapter 18: Options and accessories

Chapter contents

- 18.1 Spares and Accessories on page 100
- 18.2 Smart transducers on page 100
- 18.3 Instrument Depth, Speed and Temperature (DST) transducers on page 101
- 18.4 Instrument Depth transducers on page 102
- 18.5 Instrument Speed and Temperature transducers on page 102
- 18.6 Instrument Wind Vane transducer on page 103
- 18.7 Instrument Rotavecta transducer on page 103
- 18.8 Other transducers on page 104
- 18.9 SeaTalk^{ng}® cables and accessories on page 104
- 18.10 SeaTalk^{ng} cable kits on page 106
- 18.11 SeaTalk accessories on page 109



18.1 Spares and Accessories

Part number	Description	
A80353	Black bezel	i70s / p70s / p70Rs
A80354	Gunmetal bezel	i70s / p70s / p70Rs
A80357	Suncover	i70s / p70s
A80358	Suncover	p70Rs

18.2 Smart transducers

Smart transducers can be connected directly to the **SeaTalk^{ng}**® backbone without the need for an **iTC-5** or transducer pod.

The smart transducers listed below are compatible with the following displays:

- **i70 / i70s**
- Multifunction displays

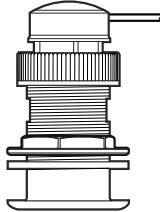
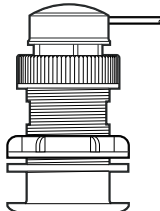
Part number	Image	Mounting	Type
A22147		Thru-Hull	DT800-12 Bronze
A80374 (replaces A22112)		Thru-Hull	DT800-12 Plastic



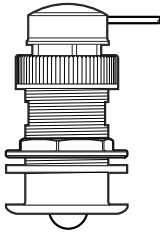
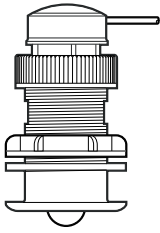

Part number	Image	Mounting	Type
A22146		Thru-Hull	DST800 Bronze
A80375 (replaces A22111)		Thru-Hull	DST800 Plastic

18.3 Instrument Depth, Speed and Temperature (DST) transducers

The DST transducers listed below are compatible with the following instrument displays:

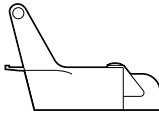
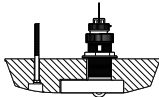
- **i40** Depth / **i40** Speed / **i40** Bidata
- **i50** Depth **i50** Speed / **i50** Tridata
- **i70** / **i70s** via **iTC-5** converter

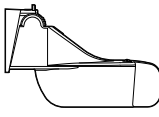
Part number	Image	Mounting	Housing
E26006-PZ		Transom mount	P66 / ST40
A26043		Thru-hull	B744V (including fairing block)
A26044		Thru-hull	B744VL (including fairing block)
E26028-PZ		Transom mount	P66



18.4 Instrument Depth transducers

The depth transducers listed below are compatible with the following instrument displays:

- **i40** Depth / **i40** Bidata
- **i50** Depth / **i50** Tridata
- **i70** / **i70s** via **iTC-5** converter

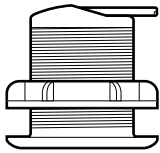
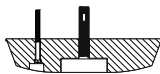
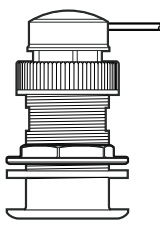
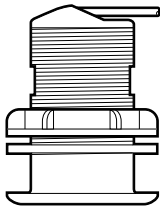
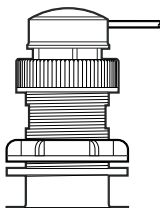
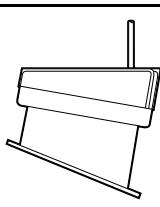
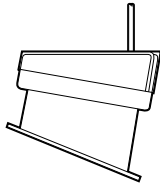
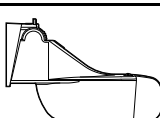
Part number	Image	Mounting	Housing
E26009		Thru-hull	P7
E26019-PZ		Thru-hull	B45 (including fairing block)
M78717		Thru-hull	B17
M78713-PZ		Thru-hull	P319
E26030		Thru-hull	P17
E26001-PZ		In-hull	P79
A80373 T70278 — (includes SeaTalk ^{ng} adaptor)		In-hull	P79S
E26027-PZ		Transom mount	P66

18.5 Instrument Speed and Temperature transducers

The speed and temperature transducers listed below are compatible with the following instrument displays:

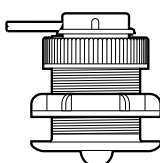
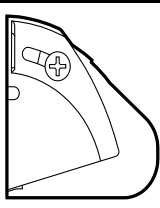
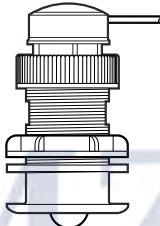
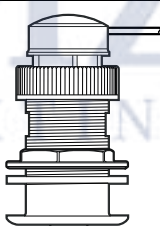
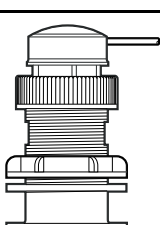

- **i40** Speed / **i40** Bidata
- **i50** Speed / **i50** Tridata
- **i70** / **i70s** via **iTC-5** converter

Part number	Image	Mounting	Housing
E26008		Thru-hull	P371
E26005		Transom mount	ST69
E26031		Thru-hull	P120 / ST800
M78716		Thru-hull	B120
E25025		Thru-hull	P17

18.6 Instrument Wind Vane transducer

The wind vane transducers listed below are compatible with the following instrument displays:

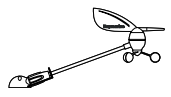
- **i60** Wind
- **i70 / i70s** via **iTC-5** converter

Part number	Image	Housing	Mounting
E22078		Short arm wind vane	Surface mount
E22079		Long arm wind vane	Surface mount

18.7 Instrument Rotavecta transducer

The wind transducers listed below are compatible with the following instrument displays:

- **i40** Wind
- **i60** Wind
- **i70 / i70s** via **iTC-5** converter

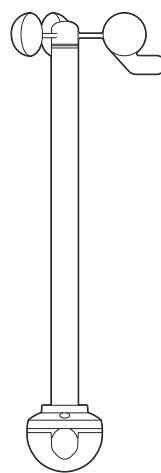
Part number	Image	Housing	Mounting
Z195		Rotavecta transducer	Surface mount



18.8 Other transducers

When connected using an **iTC-5**, the transducers listed below are compatible with the your **i70 / i70s** display:

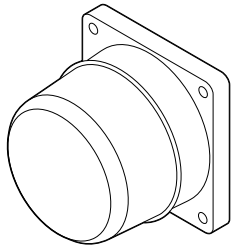
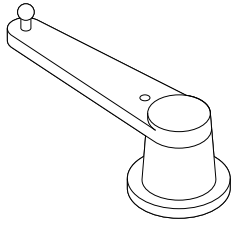
Part number	Image	Type
M81190		Fluxgate compass
M81105		Rudder Reference

18.9 SeaTalk^{ng}® cables and accessories

SeaTalk^{ng} cables and accessories for use with compatible products.



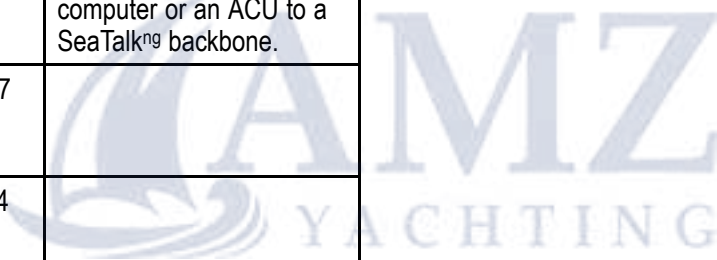

Description	Part No	Notes
SeaTalk ^{ng} starter kit	T70134	Includes: <ul style="list-style-type: none"> • 1 x 5 Way connector (A06064) • 2 x Backbone terminator (A06031) • 1 x 3 m (9.8 ft) spur cable (A06040) • 1 x Power cable (A06049)
SeaTalk ^{ng} Backbone Kit	A25062	Includes: <ul style="list-style-type: none"> • 2 x 5 m (16.4 ft) Backbone cable (A06036) • 1 x 20 m (65.6 ft) Backbone cable (A06037) • 4 x T-piece (A06028) • 2 x Backbone terminator (A06031) • 1 x Power cable (A06049)
SeaTalk ^{ng} 0.4 m (1.3 ft) spur	A06038	
SeaTalk ^{ng} 1 m (3.3 ft) spur	A06039	
SeaTalk ^{ng} 3 m (9.8 ft) spur	A06040	
SeaTalk ^{ng} 5 m (16.4 ft) spur	A06041	
SeaTalk ^{ng} 0.4 m (1.3 ft) elbow spur	A06042	
SeaTalk ^{ng} 0.4 m (1.3 ft) backbone	A06033	
SeaTalk ^{ng} 1 m (3.3 ft) backbone	A06034	
SeaTalk ^{ng} 3 m (9.8 ft) backbone	A06035	
SeaTalk ^{ng} 5 m (16.4 ft) backbone	A06036	
SeaTalk ^{ng} 9 m (29.5 ft) backbone	A06068	
SeaTalk ^{ng} 20 m (65.6 ft) backbone	A06037	
SeaTalk ^{ng} to bare ends 1 m (3.3 ft) spur	A06043	

Description	Part No	Notes
SeaTalk ^{ng} to bare ends 3 m (9.8 ft) spur	A06044	
SeaTalk ^{ng} Power cable	A06049	
SeaTalk ^{ng} Terminator	A06031	
SeaTalk ^{ng} T-piece	A06028	Provides 1 x spur connection
SeaTalk ^{ng} 5-way connector	A06064	Provides 3 x spur connections
SeaTalk ^{ng} backbone extender	A06030	
SeaTalk to SeaTalk ^{ng} converter kit	E22158	Allows the connection of SeaTalk devices to a SeaTalk ^{ng} system.
SeaTalk ^{ng} Inline terminator	A80001	Provides direct connection of a spur cable to the end of a backbone cable. No T-piece required.
SeaTalk ^{ng} Blanking plug	A06032	
ACU / SPX SeaTalk ^{ng} spur cable 0.3 m (1.0 ft)	R12112	Connects an SPX course computer or an ACU to a SeaTalk ^{ng} backbone.
SeaTalk (3 pin) to SeaTalk ^{ng} adaptor cable 0.4 m (1.3 ft)	A06047	
SeaTalk to SeaTalk ^{ng} spur 1 m (3.3 ft) spur	A22164	
SeaTalk2 (5 pin) to SeaTalk ^{ng} adaptor cable 0.4 m (1.3 ft)	A06048	
DeviceNet adaptor cable (Female)	A06045	Allows the connection of NMEA 2000 devices to a SeaTalk ^{ng} system.
DeviceNet adaptor cable (Male)	A06046	Allows the connection of NMEA 2000 devices to a SeaTalk ^{ng} system.
DeviceNet adaptor cable (Female) to bare ends.	E05026	Allows the connection of NMEA 2000 devices to a SeaTalk ^{ng} system.
DeviceNet adaptor cable (Male) to bare ends.	E05027	Allows the connection of NMEA 2000 devices to a SeaTalk ^{ng} system.



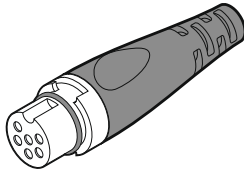

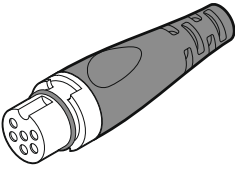
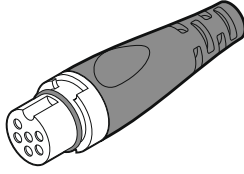

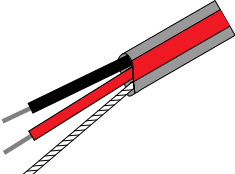
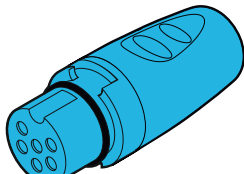
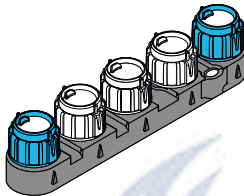
18.10 SeaTalk^{ng} cable kits

SeaTalk^{ng} starter kit (T70134)

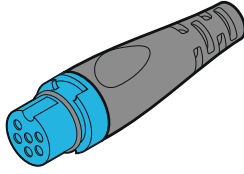
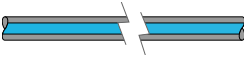
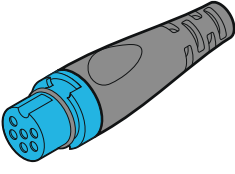
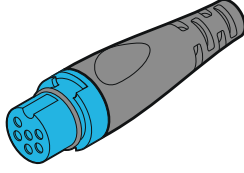
Parts included	Quantity	Connector A	Cable	Connector B	Length
Spur cable (A06040)	1				3 m (9.8 ft)
Power cable (A06049)	1				1 m (3.3 ft)
Backbone terminator (A06031)	2		N/A	N/A	N/A
5-way connector (A06064). Each connector block allows the connection of up to 3 compatible devices. When correctly terminated, a connector block forms a complete backbone. Multiple connector blocks can be daisy-chained together.	1		N/A	N/A	N/A

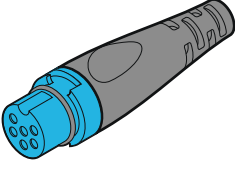
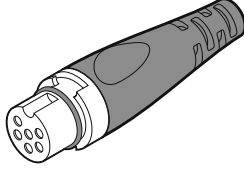
SeaTalk^{ng} Backbone kit (A25062)

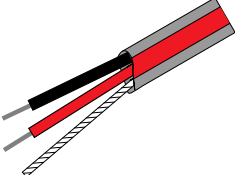
Parts included	Quantity	Connector A	Cable	Connector B	Length
Backbone cable ((A06036))	2				5 m (16.4 ft)
Backbone cable ((A06037))	1				20 m (65.6 ft)
Power cable (A06049)	1				1 m (3.3 ft)

Parts included	Quantity	Connector A	Cable	Connector B	Length
T-piece (A06028)	4		N/A	N/A	N/A
Backbone terminator (A06031)	2		N/A	N/A	N/A

SeaTalk^{ng} Evolution cable kit (R70160)

Parts included	Quantity	Connector A	Cable	Connector B	Length
Backbone cable (A06036)	2				5 m (16.4 ft)
Power cable (A06049)	1				1 m (3.3 ft)
Spur cable (A06040)	1				1 m (3.3 ft)
ACU / SPX power cable (R12112) (for powering the SeaTalk ^{ng} backbone from the autopilot system.)	1				0.3 m (1.0 ft)
5-way connector (A06064). Each connector block allows the connection of up to 3 compatible devices. When correctly terminated, a connector block forms a complete backbone. Multiple connector blocks can be daisy-chained together.	1		N/A	N/A	N/A

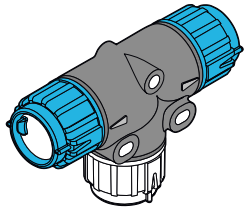
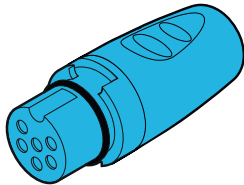
Parts included	Quantity	Connector A	Cable	Connector B	Length
T-piece (A06028)	2		N/A	N/A	N/A
Backbone terminator (A06031)	2		N/A	N/A	N/A

SeaTalk^{ng} converter kit (E22158)

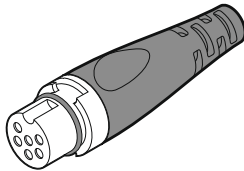
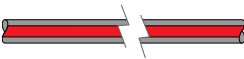
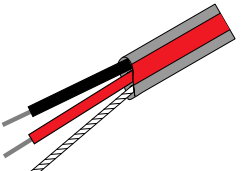
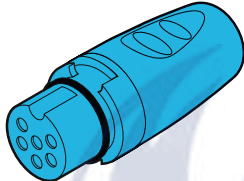
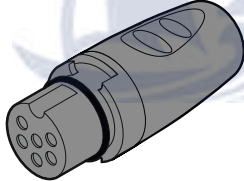
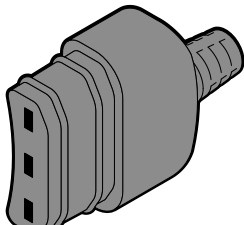
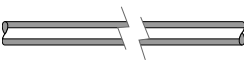
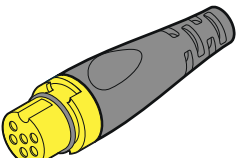
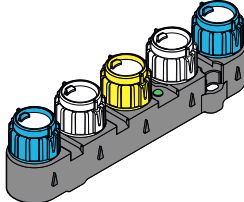
Parts included	Quantity	Connector A	Cable	Connector B	Length
Power cable (A06049)	1				1 m (3.3 ft)
Backbone terminator (A06031)	2		N/A	N/A	N/A
Blanking plug (A06032)			N/A	N/A	N/A
SeaTalk (3 pin) adapter cable (A06047)	1				0.4 m (1.3 ft)
SeaTalk to SeaTalk ^{ng} converter (E22158). Enables the connection of SeaTalk devices to a SeaTalk ^{ng} system.	1		N/A	N/A	N/A

18.11 SeaTalk accessories

SeaTalk cables and accessories for use with compatible products.

Description	Part No	Notes
3-way SeaTalk junction box	D244	
1 m (3.28 ft) SeaTalk extension cable	D284	
3 m (9.8 ft) SeaTalk extension cable	D285	
5 m (16.4 ft) SeaTalk extension cable	D286	
9 m (29.5 ft) SeaTalk extension cable	D287	
12 m (39.4 ft) SeaTalk extension cable	E25051	
20 m (65.6 ft) SeaTalk extension cable	D288	





Appendix A Supported NMEA 2000 PGN list

PGN	Description	Received	Transmitted
59392	ISO Acknowledgment	•	•
59904	ISO Request	•	
60928	ISO Address Claim	•	•
126208	NMEA - Request group function	•	•
126464	PGN List – Receive / Transmit PGN's Group function	•	•
126992	System Time	•	•
126996	Product Information	•	•
127237	Heading/Track Control	•	
127245	Rudder	•	•
127250	Vessel Heading	•	•
127251	Rate of Turn	•	•
127257	Attitude	•	
127258	Magnetic Variation	•	•
127488	Engine Parameters, Rapid Update	•	
127489	Engine Parameters, Dynamic	•	
127493	Transmission Parameters, Dynamic	•	
127496	Trip Parameters, Vessel	•	
127497	Trip Parameters, Engine	•	
127498	Engine Parameters, Static	•	
127505	Fluid Level	•	
127508	Battery Status	•	
128259	Speed	•	•
128267	Water Depth (below transducer)	•	•
128275	Distance Log	•	•
129025	Position, Rapid Update	•	•
129026	COG & SOG, Rapid Update	•	•
129029	GNSS Position Data	•	•
129033	Time & Date	•	•
129038	AIS Class A Position Report	•	

PGN	Description	Received	Transmitted
129039	AIS Class B Position Report	•	
129040	AIS Class B Extended Position Report	•	
129041	AIS Aids to Navigation	•	
129044	Datum	•	•
129283	Cross Track Error	•	•
129284	Navigation Data	•	•
129291	Set & Drift, Rapid Update	•	
129801	AIS Addressed Safety Related Message	•	
129802	AIS Safety Related Broadcast Message	•	
129809	AIS Class B CS Static Data Report Pt A	•	
129810	AIS Class B CS Static Data Report Pt B	•	
130306	Wind Data	•	•
130310	Environmental Parameters	•	•
130311	Environmental Parameters	•	•
130576	Small Craft Status	•	
130577	Direction Data	•	







www.raymarine.com

